

LARIUS

PAINT SPRAYING UNITS

USER MANUAL FOR HVLP SYSTEM



Q4 GOLD

WWW.LARIUS.COM

CONTENTS

Contents	1
Safety Precautions	2
Air Control Valve & Diaphragm	3
Spray pattern	4
Distance & Pressure Tube.	5
Spraying techniques	6
Aircap selection	7
Latex & Viscosity	8 - 9
Viscosity guide	9
Cleaning	9 -10
Pressure pot use	10
Finish Problems	11
Spray Gun Problems	12 -13
Needle Packing & Seals.	14
Parts disassembly	15
Turbine problems	15
Parts diagrams.	16 -18
Service information.	19
Warranty information	20
CE Declaration	Back Cover

Please read these instructions carefully before using the equipment

ELECTRICAL

The turbine is powered by a 3-stage or 4-stage (depending on the model) single speed, bypass, air turbine. **This turbine must be connected to the correct voltage.** Please check the label on the base for voltage rating.

ELECTRICAL CONNECTION

For your safety and protection, we have equipped your turbine with a three-pronged grounding plug on the service cord. This must be plugged into a properly grounded 3-pronged receptacle. (For some countries this may be a 2-pin grounded plug).

SAFETY WARNINGS:

THE TURBINE MUST NOT BE USED IN AN AREA CONTAMINATED BY VOLATILE OR FLAMMABLE MATERIALS SINCE SPARKING CAN BE EXPECTED IN THE NORMAL OPERATION OF THE MOTOR. THIS COULD IGNITE THE CONTAMINANTS CAUSING A DANGEROUS EXPLOSION. KEEP THE TURBINE AT LEAST 18 FEET (5.5 METERS) AWAY FROM THE SPRAYING AREA. FOR HEALTH REASONS, ALWAYS WEAR A RESPIRATOR. PLEASE CHECK WITH THE LOCAL JURISDICTION.

THE SPRAY GUN MUST NEVER BE POINTED AT SOMEONE'S FACE.

THE OPERATOR MUST WEAR SHOES AND THE FLOOR MUST NOT BE WET.

FILTER(S)

The Q-Series turbines and Super models use just ONE large filter . **The turbine case does not need to be taken apart to replace the filter.** To remove, simply turn the turbine on its side and pull the filter out. Wash in solvent and **dry** before replacing. All filters are a friction fit. When replacing, push the filter in by hand and finish up by using a screwdriver through the square holes to lever the filter into position. **The filter must fill the entire filter enclosure and always be FLUSH with the base of the turbine case.** The Mini-Mite Turbines use 2 filters, one fine and one coarse. Looking from the front of the turbine please insert the fine filter to the left side (near the 'F') and the coarse to the right side. It is important to keep the turbine as far away as possible from the spraying area (and workshop dust). If the filters become badly clogged, cooling air will be restricted - this may cause serious damage to the motor .

THE TURBINE MUST NOT BE PLACED UP HIGH. PLACE ON THE FLOOR - . THIS PREVENTS BLOWBACK INTO THE MOTOR FROM THE BENT HOSE.

AIR CONTROL VALVE

The air control valve 2032 is located on the hose next to the brass quick-connect. It provides you with a means of controlling the air flow through the gun. It offers you fingertip control when you need it to reduce bounceback and overspray. There is one thing to remember about the air control valve - it is the '**last in the chain**' of operations after...

- 1) Thinning the paint
- 2) Adjusting the shape and size of the spray pattern
- 3) Adjusting the flow of paint through the gun.

After performing these operations, you should spray a few passes onto a scrap piece of plywood or cardboard. This will allow you to determine if the paint (generic word for any type of coating) levels nicely. If there is 'orange-peel' then you must thin the product more. Once the gun is producing a perfect finish with full air, you may then experiment with turning the air down until bounceback is reduced to a minimum. However, if orange-peel results, you have no option but to turn the air up again a slight amount. With heavier paints (such as latex) spraying may be done with the valve fully open (or even removed).

PLASTIC DIAPHRAGM

The 1 Quart pressurized cup has a plastic diaphragm (not found in the Gravity Spraygun). This diaphragm prevents paint from entering the pressure tube. The small air hole in the diaphragm should not be placed directly below the air hole in the nipple. Position the diaphragm hole to the rear of the cup. The spraygun can be turned to different angles when spraying, however the cup should never be higher than the gun (above horizontal). To remove the diaphragm for cleaning, grab the small tab and slide it gently down the metal fluid tube. The diaphragm can be washed in thinner. **Note: There is no diaphragm on the Gravity Cup.**

HOSE CONNECTION

Connect the hex nut at the end of the hose (female connector) to the turbine air outlet. **It is not necessary to use a wrench to tighten this hex nut. Overturning could cause the manifold to rotate and break the internal seal to the motor.**

GETTING STARTED

Your Spraygun has been adjusted at the factory and is ready for spraying. To clean out any impurities that may have accumulated during assembly or shipping, we recommend spraying a small quantity of clean paint thinner through the gun. Before tackling any serious spraying, experiment with the gun on a scrap piece of wood until you become familiar with all the controls.

CHANGING THE SHAPE OF THE FAN

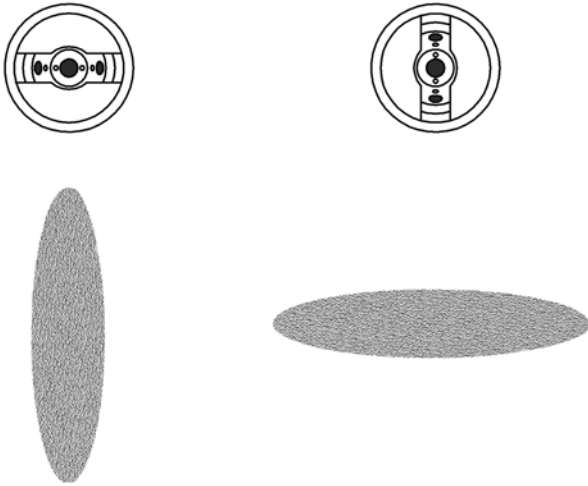

A) Loosen the collar. Turn the air cap to the horizontal position then re-tighten to collar to lock it into place. This setting produces a vertical spray pattern. This pattern is used more than any other by experienced spray painters.

B) Setting the air cap in a vertical position produces a horizontal spray pattern. The horizontal fan pattern is the most useful for painting vertically such as a doorframe.

CHANGING THE SIZE OF THE FAN

To produce a smaller fan pattern, turn the pattern control knob counter-clockwise. Because the spray pattern size is now much smaller, **you must turn down the amount of paint** spraying through the nozzle. If you do not do this, you will get runs.

To set the fluid output, simply turn the fluid knob clockwise for more 'paint' and counter-clockwise for less. Once you set the fluid to your liking, you can leave it in this position - unless of course, you change the size of the fan pattern.

For the very smallest pattern (less than about 1 1/2"), you must move the gun closer to the workpiece - but don't forget to reduce the amount of paint at the fluid knob (rear of gun) when you do this.

SPRAY GUN DISTANCE

The spray pattern is fan-shaped, so for a larger sized fan you do not have much choice - you will be at or close to the **maximum 8" distance**. It's impossible to produce a large spray pattern if you hold the spraygun too close to the object - there is no room for the fan pattern to expand.

As you move closer with the gun, the fan will become a smaller size. So for instance, what was 10" wide at a distance of 8" becomes about 2" fan at 2" distance.

When you want to paint something that is, let's say, 2" across and 6ft long - you will find it much easier to follow the object if you move the gun closer . This will give you the ability to control your pass from side to side properly without wandering all over the place. Plus it will reduce overspray . Imagine spraying 1/2 chair spindles from 8" away with a spraygun when you don't have bristles (as you do with a brush) to help guide you - it's very difficult. So simply adjust the pattern to be smaller and cleaner and move in close until the fan is the exact same size as the spindles. Once you are close, you will be able to guide the spraygun easily and it will not be as important to have a completely steady hand.

As an aside - it is usually not possible to bring the sprayhead close to the object with other methods of spraying (high-pressure for instance). Doing so would produce bounceback. The pressure is much less with turbine HVLP so this is not a problem.

THE PRESSURE TUBE

When spraying, never turn the gun upside down. The cup should never be higher than horizontal. The 1 Quart cup must always be lower than the gun. (On the gravity gun, it's the opposite, the cup must be higher than the gun - at least no lower than horizontal).

Upon stopping spraying for any reason, first turn off the turbine. Disconnect the hose and then carefully open the cup to release pressure. It's best to hang up the gun - use any type of hook or rod for this.

Do not stand the gun on a bench or even the floor because it will always be prone to falling over which could damage the spraygun and cause paint to flow up the pressure tube and into the spraygun.

Any paint in the pressure tube or nipples the tube is attached to, causes reduced amounts of paint through the gun. This is because the cup pressure is too low. Air is being restricted through the nipples by the paint blockage. The symptom will be little or no paint and the reason will always be the nipples or pressure tube being clogged with dried paint. We suggest always having extra pressure tubes on hand.

ACTUAL SPRAYING TECHNIQUES.

The spraygun should be held perpendicular to the surface at all times. HOLD THE GUN NO MORE THAN 8" (20cm) AWAY FROM THE SURFACE TO BE PAINTED. But closer is ok.

CORRECT METHOD

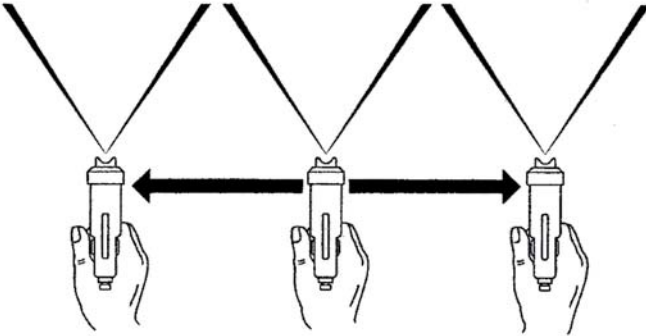

Start moving the spraygun in the direction you want to spray and press the trigger. Between each successive pass, overlap by about a quarter .

INCORRECT METHOD

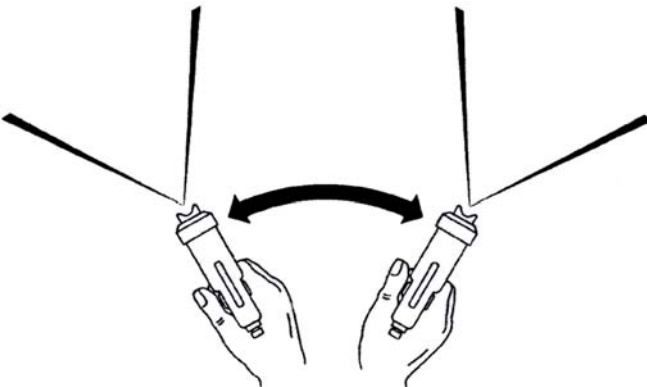

Never, for any reason, point the spraygun directly at the face, or head of a person.

AIRCAP SET SELECTION

The fluid nozzle and needle MUST always match exactly. Size No.4 is standard with all sprayguns. No. 3 or No. 4 can be used for any type of fine-finishing application. The difference between the two is that the #4 allows for more fluid output. This is desirable when spraying fast drying lacquers. It allows you to spray faster and wetter to obtain better leveling of the finish. 4 additional setups are available as accessories. Generally speaking, the quality of atomization and finish suffers as you go to the larger size setups (No.5 and 6).

AIRCAP SET

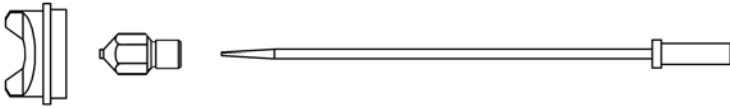

If you do not intend on spraying walls & ceilings then the only two setups you would ever need would be the #3 Fine and Standard #4.

No. 2 (Part 8050-2) .7mm (.027") FINE OUTPUT

SHADING, STAINS,

No. 3 (Part 8050-3) 1mm (.039") FINE OUTPUT

WATER-BASED LACQUERS, ACRYLICS, POLYURETHANE, STAINS.

No. 4 (Part 8050-4) 1.4mm (.055") MEDIUM OUTPUT - STANDARD

Similar to No. 3 but more coverage. Best for AUTOMOTIVE ENAMELS, NITROCELLULOSE LACQUER and LATEX for a finer finish. Also ideal for VARNISHES, PRIMERS, OIL-BASED PAINTS and STAINS.

No. 5 (Part 8050-5) 1.8mm (.070") HIGH OUTPUT

Larger surfaces, thick layers, spotted effects. SEALERS, VARNISH, POLYURETHANE, OIL BASED PAINTS, ENAMELS, EPOXY, PLASTIC, ADHESIVES, FLOOR PAVING PAINTS, LATEX, ETC.

No. 6 (Part 8050-6) 2.2mm (.086") EXTRA HIGH OUTPUT

Very heavy flows, fast coverage. STONE FINISH PAINTS, TEXTURE COATING, INDUSTRIAL PRIMERS, MULTI-FLECK PAINTS, LATEX (on walls, ceilings) ETC.

A WORD ABOUT LATEX

Although latex paint was never originally intended to be sprayed, a professional finish can be achieved by following a few simple rules. (Please do not confuse latex with the newer water-based coatings). For work such as cabinetry or trim, our equipment can be used successfully with latex paint. The latex will have to be thinned with **WATER** - approximately **20-30% depending on the brand of paint**. And to improve the finish even more, you can use an additive that will slow down the drying process so that the paint levels out nicely. One product available is FLOETROL from the FLOOD Company in Ohio. In the USA Call 1-800-321-3444 for your nearest supplier. (In the U.K. 0845-0618899).

The ideal Aircap size setup is the #4 for household trim, louver doors etc. The Latex paint should be 'finish-quality' and not a cheaper grade.

When spraying Latex, please adjust the fluid knob to limit the paint to a finer spray. This will increase the ratio of air to paint and result in better atomization and a beautiful finish. (Factually speaking, it doesn't increase the ratio of air to paint but does the opposite - it allows the air atomizing power to work on less paint thereby improving the quality of atomization). Also, it is usually helpful to remove the air control valve so that more air passes through the spraygun. Finally, adjust the pattern to a maximum size of 8" - 9" (20cm) - smaller is ok.

Although it is possible to use our equipment for house painting (walls), and many end users do, we feel that an airless gun or power roller is better suited for that kind of job. However, if you decide to do this kind of work, you will need the #6 Aircap set.

VISCOSITY

Follow the viscosity guide chart. You will eventually learn to thin the material by experience. Traditionally, lacquers were thinned 50/50 even for high pressure spraying but this much thinning is not necessary. However, coatings manufacturers are reformulating constantly so it is always advisable to check with them. Thinning a product excessively causes more overspray as well as runs. Stringent air quality controls in some geographic locations may prohibit reducing by more than a certain percentage. Please check with the local jurisdiction in this matter.

Remember, when you buy a can of paint, lacquer, polyurethane, varnish etc. over the counter, it will most likely be formulated for brushing. That means, it will be too viscous (thick) and will require thinning to spray successfully. This is especially true if there is no mention of spraying on the instructions on the can. Check with the manufacturer of the coating to obtain advice on thinning their product.

VISCOSITY GUIDE

To test the viscosity of the paint material, fill the viscosity cup to the brim and time how long it takes for the liquid to empty out through the hole. We recommend you experiment to find the ideal viscosity for your application and record the information for the next time.

Always check with the manufacturer of the coating for assistance in thinning for spraying. If their product is only designed to be brushed, they may not be too helpful. But remember that any type of coating can be sprayed if it is thinned correctly and you have installed the ideal aircap set.

The chart below is only an approximate guide denoting how many SECONDS it takes for the material to flow out of the viscosity cup.

Auto Cellulose	18 - 20	Primers	30 - 40
Lacquers	18 - 20	Sanding Sealers	20 - 22
Enamels	20 - 25	Stains	Undiluted
Latex	20 - 30	Creosote	Undiluted
Oil-based	20 - 25	Polyurethanes	20 - 25

We suggest thinning around 25% to begin with but this may contravene the air quality control laws for your location. The solvent used for thinning is usually the solvent mentioned on the can (instructions for 'cleaning the brushes'). However, please check with the coatings manufacturer .

HVLP spraying is more friendly to the environment than most methods of spraying. It reduces appreciably the amount of unnecessary misting and fogging (overspray) associated with high-pressure spraying. Spraying with Nitrocellulose lacquer can be **hazardous. The lacquer, fumes and overspray are toxic, flammable and explosive.** If spraying must be done inside an enclosed area, **ventilate well.** Spray close to an open window or door and situate a fan to draw out the fumes (an explosion-proof motor and explosion proof lighting will be necessary). PLEASE CHECK WITH THE LOCAL AUTHORITY HAVING JURISDICTION ON THIS MATTER.

CLEANING

To clean the gun after each use, empty all paint from the cup. Use a solvent soaked rag to clean the residue in the cup. Then, spray some clean solvent through the gun into a clean rag (to avoid filling the room with unnecessary spray) or a bucket. Repeat until the inside of the fluid passages in the gun, metal fluid tube etc. are clean. Use the wet rag to wipe off the aircap and tip of the fluid nozzle. The Aircap can be soaked in thinner.

Back-flushing is not necessary. Do not restrict the fluid nozzle when cleaning - this will drive thinned paint up the pressure tube and into the spraygun which is undesirable.

If this type of cleaning is done while the paint is still wet in the gun, it should be all that is necessary to keep the gun clean enough for next time. Do not leave liquids in the cup overnight or for long periods. **The Gravity Gun can be cleaned without hooking up to the hose. Simply wind out the fluid knob all the way and pull the trigger - the thinner (solvent) will stream out of the fluid nozzle. Repeat until clean.**

PLEASE DO NOT USE A WIRE BRUSH OR ANYTHING METAL TO CLEAN THE GUN OR CUP AS THIS WILL CAUSE DAMAGE.

DO NOT disassemble the cup assembly - threads in your cup have been sealed at the factory to prevent leakage under pressure.

The standard 1 quart (1000cc) cup can be used with most coatings (including water-based). Also available as an accessory is our 2041T teflon-coated cup.

CAUTION: Never soak the complete spraygun in solvent as this removes the grease from the parts and distributes thinned paints throughout the air passages. It could also damage internal parts such as the spindle valve or valve seals. It may however, be necessary sometimes to soak the aircap and nozzle. **You may soak only the metal parts in solvent and clean with the soft bristle cleaning brush 9045.** To reassemble, first oil or grease all moving and threaded parts.

CAUTION: Do not store the gun with the cup clamped down hard as this will cause the gasket to flatten out. Do not lay the gun down on its side with liquid material in it.

PRESSURE POT USE

To use the gun with a pressure pot, remove the cup assembly and the pressurizing tube. Connect your material line (fluid hose) to the fluid coupler on the gun. Because you are using air from the turbine, you must block off the air that would normally go from the pressure pot to the gun. This can be capped with a brass threaded cap or the coupler can be removed and a threaded brass plug inserted. The hose connector at the base of the handle must be switched to hose connector . The does not have the pressurizing nipple.

A COMPRESSOR IS NEEDED TO PRESSURIZE THE POT.

Set the compressor to between 6-8 PSI. This is enough to push the paint material up to the gun. For spraying at greater heights (over 8 feet), more fluid pressure may be necessary . The fluid pressure should never be set at more than 20 PSI. If you find a higher pressure is needed, we advise you to check the material hose for paint blockage.

FINISH PROBLEMS

ORANGE PEEL - If the finish is rough and resembles orange peel then the material is too thick. (Or perhaps you have the air control valve turned down - please check that it is fully open). The 'paint' will not atomize properly and the surface will be spotty. To remedy this, add more thinner (or appropriate solvent). For fast drying products such as lacquers, you may also want to add a lacquer retarder. This will slow the drying time allowing the material to flow out and level nicely.

Retarders are available for other coatings too, such as Penetrol for oil-based paints or Floetrol for latex house paints. These products go under different names such as Flow-Out Additives etc. Please check with the coatings manufacturer.

NOTE: With the newer water-based materials 'orange peel' is usually a result of spraying on too thick a film. **Try spraying an extremely THIN FILM, but still WET coat.** With most other coatings, orange peel is caused by material being too thick or not enough atomizing power. This is why we suggest leaving the air control valve fully open when experimenting with a new coating material, otherwise it will cause confusion. If the the air control valve is fully open (or perhaps removed for Latex spraying) then orange peel can only be one cause - the material is too thick and must be thinned.

GRITTY FINISH - If the material is too thin, it is likely to run or be over-atomized, producing a rough gritty finish. Try thinning the product less and spraying a wetter coat.

BLUSHING - Blushing is the common term used when the finish looks cloudy and white (sometimes also called blooming). It is caused by moisture and is especially a problem when operating high pressure spray equipment. The moisture comes from the compressor. This problem does not usually occur when using the turbine because the air from the turbine is warm, dry and uncontaminated. However, it is possible on very humid days to encounter slight blushing. Using a retarder will often allow moisture to escape, preventing the milky look.

FISH EYES - If you are refinishing furniture or pianos, fish eyes could become a problem. The cause is usually silicone or oil from polish which has been liquified by the paint stripper that has now soaked into the bare wood. This silicone prevents the lacquer from adhering to the wood. One way to sometimes correct this is to seal in the silicone by misting on two or three light coats of lacquer. Then spray on a regular wet coat. We *do not* recommend the use of a product known as 'Fish-Eye Drops' which is essentially liquid silicone. Silicone will only contaminate the gun even further. Anything that comes into contact with the silicone becomes contaminated - such as; rags, aprons, bench tops, gloves.

SPRAYGUN PROBLEMS

NO PAINT (OR VERY LITTLE PAINT)

THIS IS THE MOST COMMON PROBLEM ENCOUNTERED-

The air passing through the plastic tube to pressurize the cup is blocked. This means that either the tube itself, the check valve, or one of the two nipples is blocked. A pipe cleaner can be used for cleaning the hole in the nipple. Please see more info on the pressure tube' - **Page 5**

- Pressurizing tube and/or nipples are blocked
- The cup is not tightened down sufficiently by the quick-release lever or the cup gasket is worn and leaking air
- The cup is empty
- The metal fluid tube is blocked with paint - rare
- The fluid coupler is blocked with paint - rare

UNEVEN SPRAY PATTERN

One of the holes in the aircap may be blocked. Or, the paint could be dirty and is partially blocking the fluid nozzle. Remove the aircap and clean by soaking in solvent and using the soft bristle brush or a rag. NEVER use metal objects to clean holes in the aircap.

LEAKAGE

If paint material comes out of the fluid nozzle **without** pulling the trigger...

- The needle is not seating in the fluid nozzle properly
- The needle packing may be too tight preventing the needle from moving
- Foreign matter could be trapped between the needle and fluid nozzle
- The needle or fluid nozzle could be damaged or worn
- Loose fluid nozzle
- Wrong nozzle size installed

CUP LEAKS

- Oil above and below the lever to smooth the lever action
- Change gasket/diaphragm - oil lever first to check
- Leak around nipple - use Loctite to seal
- Leak around side pins - use Loctite to seal
- Leak through lid - remove nut under lid - use Loctite

THE TRIGGER IS SLUGGISH

- The needle packing is too tight - see ADJUSTING THE NEEDLE PACKING. Page 14
- Bent needle
- The valve seal is damaged - replace

POOR SPRAY PATTERN

- Damaged needle or nozzle
- Nozzle is clogged
- Air holes in air cap clogged
- Aircap screwed in too tight
- Gun too far from surface (max. 8" - 20cm)

PAINT AT THE AIR NOZZLE HOLES

- The fluid nozzle is loose and material is leaking around it - tighten with a adjustable wrench or 7/16" socket.
- Paint is entering the gun via the pressure tube (very rare) and being blown through the barrel to the aircap - see HOW TO PREVENT PAINT ENTERING THE PRESSURE TUBE. Page 4

GUN SPRAYS IN A PULSATING MANNER

- The needle packing has worn a little or is loose. Tighten
- The cup is almost empty
- The cup lid is not tight - air is escaping
- The clear plastic pressure tube is leaking air . Replace
- The pressure tube and/or nipple is clogged. Clear or replace
- Gravity gun - turn the collar IN to alleviate back-pressure

EXCESSIVE OVERSPRAY

- The spray pattern size is too large for the item you are spraying
- The gun is being held too far away - should be 8" max. (20cm)
- Trigger on and off as you pass over the edges of the item
- The product is too thin - try thinning less
- Reduce the air by turning the air control valve to the point where overspray is minimized but the finish still looks good
- For ideal and comfortable spraying conditions, you should install an extraction fan.* If you are spraying a flammable, combustible product such as nitrocellulose lacquer , you must inst all an explosion-proof fan (and explosion-proof lighting and switches)

*** Please check with the local jurisdiction on this matter**

ADJUSTING THE NEEDLE PACKING

The needle packing must be tight enough to prevent any leakage of paint material. It should however, allow the needle to glide smoothly through it. If the packing is too loose, you will see a small amount of paint where the needle passes through the small needle packing nut. Using the supplied wrench, gently tighten the nut. This is a good time to apply a spot of oil to the needle where it passes through the packing nut.

The needle packing is made from long-lasting teflon and should never need replacing. But, if necessary, it can be replaced by removing the needle, then the needle packing nut. Using a sharp tool, pry out the needle packing. Be careful not to damage any threads. Drop in the replacement needle packing and re-assemble.

Like all spraygun manufacturers, we use 'stock' stainless steel rod for the needle. This rod can differ in diameter slightly with each production run. So if you change a No. 3 for a No. 4 needle, one could be a slightly oversized diameter and one slightly undersized. This may necessitate adjusting the needle packing.

THE SPINDLE VALVE ASSEMBLY

The spindle valve assembly can be removed as follows.

- 1) Remove the fluid knob, spring, and gently pull out the needle assembly.
- 2) Turn out the fluid screw nut (a socket is preferable to a wrench).
- 3) Remove the spring and gently pull out the spindle valve assembly.

To replace, reverse the procedure being careful to center the spring onto the spindle valve. Also, before tightening in the fluid screw nut please ensure that the spindle is centered in the seal. The end of the spindle is visible through the hole in the fluid screw nut.

THE SPINDLE VALVE SEALS

Removal and replacement of the spindle valve seals is simple. Any thin, flat tool such as a screwdriver can gently pry out the seal. To replace, firmly push the seal into place. Small leaks of air are not important and will have absolutely no effect whatsoever on the atomization process.

The seals are designed to be durable and long-lasting under normal working conditions. We do not recommend the practice of dunking the whole spraygun into a container of solvent. This may damage the valve and valve seals.

SETTING DIRECTION OF NIPPLE ON HANDLE

If for some reason you remove the hose connector you will have to re-set the direction of the nipple. The direction of the nipple at the air hose connector (base of handle) should be facing towards the nipple on the cup lid. To re-adjust, loosen jamb nut, then turn the hose connector to the correct position and tighten jamb nut. **The aluminum tube handle is NOT removable.**

CLEANING FLUID COMPONENTS

All fluid components in the spray gun are manufactured from stainless steel. To clean, flush solvent through the spraygun while the paint is still wet inside the gun.

For a more thorough cleaning, remove all parts at the front of the barrel. (collar, aircap, fluid nozzle etc.) Also remove the needle (from the rear of the gun). Please note* the parts behind the nozzle are not removable. The fluid coupler (where the cup assembly attaches) is not removable.

If necessary, use the supplied cleaning brush wetted with solvent to remove paint particles from inside the fluid coupler and from the area where the nozzle was installed. **Please do not soak the whole gun in solvent**, this should never be necessary and it could damage the valve assembly and valve seals.

The cup assembly can also be removed by loosening the swivel nut at the top of the fluid tube. Upon re-installation, please do not overtighten the swivel nut - it is basically a hollow nut. If you apply extreme torque, you can cause damage to the nut.

TURBINE PROBLEMS

NO POWER - Check your power outlet. Also, try re-setting the breaker on the back of the turbine by pressing it once.

**PLEASE DO NOT TRY TO SERVICE THE TURBINE YOURSELF.
CONTACT US FOR TECHNICAL ASSISTANCE.**

In an emergency, where you cannot have any 'down time' you could take the turbine unit to any Vacuum Repair Store. They are very familiar with the turbine motor and can check the electrical components very easily. The problem is most likely a loose electrical connection.

Xpc SPRAY GUN

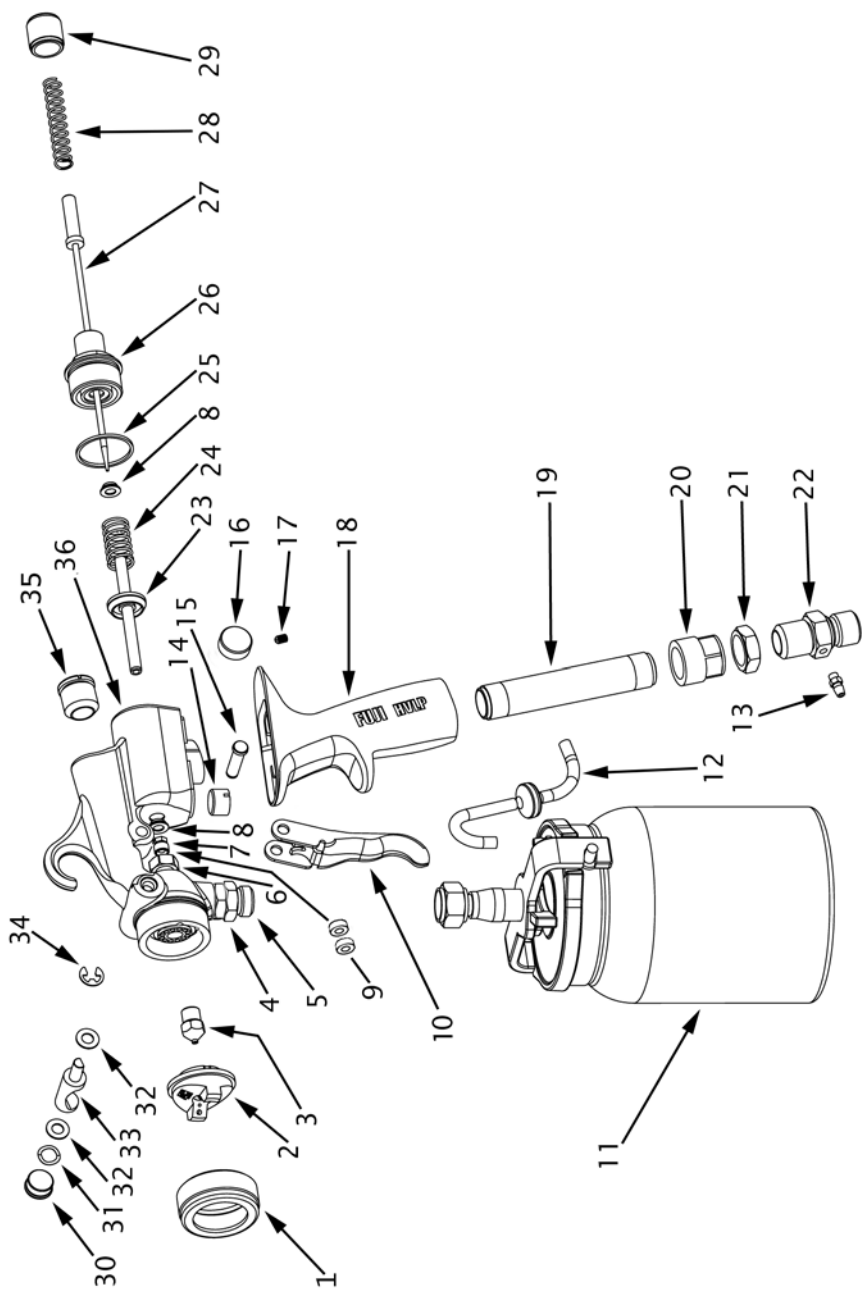

ITEM	PART	NAME	ITEM	PART	NAME
1		Collar	19		Handle Tube **
2		Aircap	20		Handle Tube Nut
3		Fluid Nozzle	21		Jamb Nut
4		Jamb Nut **	22		Hose Connector
5		Fluid Coupler **	23		Valve Assembly
6		Jamb Nut **	24		Valve Spring
7		Needle Packing Nut	25		Fluid Screw Nut Seal
8		Valve Seal	26		Fluid Screw Nut
9		Needle Packing (2)	27		Needle Assembly
10		Trigger	28		Needle Spring
11		Cup Assembly	29		Fluid Knob
12		Pressure Tube	30		Air Plug
13		Nipple	31		Wave Spring
14		Threaded Plug **	32		Shaft Washer
15		Trigger Barrel	33		Air Deflector
16		Pattern Control Knob	34		Retaining Ring
17		Allen Screw	35		Rear Barrel Plug
18		Handle	36		Gun Body

Please Note: Parts shown with ** are not removable

CUP ASSEMBLY 2042

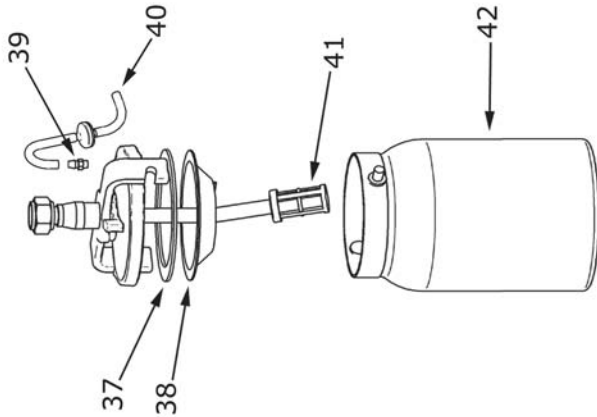

GRAVITY GUN PARTS

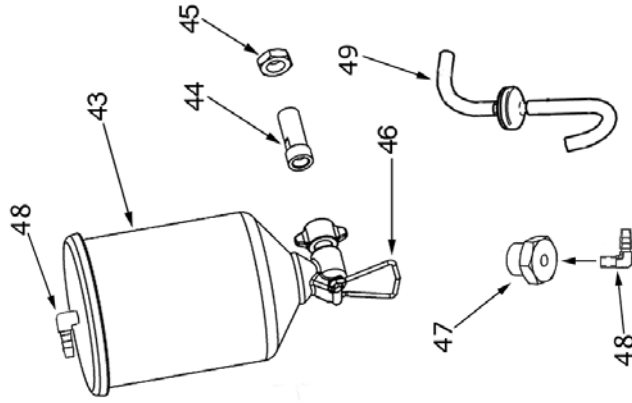

ITEM	PART	NAME
37		Cup Gasket
38		Diaphragm
39		Nipple
40		Pressure Tube
41		Paint Strainer
42		1 Qt. Cup
43		Gravity Cup
44		G-Fluid Coupler**
45		Jamb Nut-G**
46		Fold-Down Stand
47		Nipple Adaptor
48		90 Degree Nipple**
49		Pressure Tube-L

Please Note: Parts shown with ** are not removable

LARIUS

LARIUS SRL - 23801 CALOLZIOCORTE (LC) – ITALY – Via Stoppani, 21 –

Tel. 0341/621152 – Fax 0341/621238

E-mail: acquisti@larius.com – Internet: <http://www.larius.com>