

DALI

OPERATING AND MAINTENANCE INSTRUCTIONS



LARIUS[®]
PAINT SPRAYING EQUIPMENT

ENGLISH

CE





Due to a constant product improvement programme, the factory reserves the right to modify technical details mentioned in this manual without prior notice.

This manual is to be considered as an English language translation of the original manual in Italian. The manufacturer shall bear no responsibility for any damages or inconveniences that may arise due to the incorrect translation of the instructions contained within the original manual in Italian.

LARIUS

ELECTRIC DIAPHRAGM PUMP

INTRODUCTION	p.1	L WARNING PLATE	p.11
A WORKING PRINCIPLE	p.2	M PROBLEMS AND SOLUTIONS	p.12
B TECHNICAL DATA.....	p.2	N CORRECT PROCEDURE OF DECOMPRESSION.....	p.13
C DESCRIPTION OF THE EQUIPMENT	p.3	O COMPLETE HYDRAULIC BODY.....	p.14
D TRANSPORT AND UNPACKING	p.4	P DALÌ PETROL - DALÌ LINER.....	p.16
E SAFETY RULES.....	p.4	Q COMPLETE COLOUR BODY	p.18
F SETTING-UP.....	p.5	R HIGH PRESSURE GUN "AT 250"	p.21
G WORKING.....	p.8	S SUCTION SYSTEM.....	p.22
H CLEANING AT THE END OF THE WORK	p.9	T TROLLEY	p.23
I ROUTINE MAINTENANCE	p.10	U ACCESSORIES.....	p.25

				
Read this operator's manual carefully before using the equipment. An improper use of this machine can cause injuries to people or things.	It indicates an accident risk or serious damage to equipment if this warning is not followed.	It indicates a fire or explosion risk if this warning is not followed.	It is obligatory to wear suitable clothing as gloves, goggles and face shield.	It indicates important recommendations about disposal and recycling process of products in accordance with the environmental regulations.

**WE ADVISE THE USE OF THIS EQUIPMENT ONLY BY PROFESSIONAL OPERATORS.
ONLY USE THIS MACHINE FOR USAGE SPECIFICALLY MENTIONED IN THIS MANUAL.**

Thank you for choosing a LARIUS S.R.L. product. As well as the product purchased, you will receive a range of support services enabling you to achieve the results desired, quickly and professionally.

A WORKING PRINCIPLE

The **LARIUS DALÍ** unit is defined as an “electric diaphragm pump”. An electric diaphragm pump is used for high pressure paint spraying without air (known as “airless”).

The pump is powered by an electric (internal combustion) motor coupled with a cam shaft. The shaft acts on the hydraulic piston as it pumps oil from the hydraulic case and sends the suction diaphragm into fibrillation. When the diaphragm moves, it creates

a vacuum. The product is sucked up, pushed towards the pump outlet and sent to the guns through the flexible hose. A hydraulic valve on the hydraulic case head allows setting and checking the pressure of the paint product at the pump outlet. A second hydraulic safety valve to avoid over-pressure, ensures total equipment reliability.

B TECHNICAL DATA

	DALI
SUPPLY (single-phase, Three-phase internal combustion supply, petrol-diesel)*	220V 50Hz / 110V 60Hz 380V 50Hz
MOTOR POWER Mono-threephase Internal combustion	1,1 kW 3 HP
MAX. WORKING PRESSURE	200 bar 2900 psi
MAX. DELIVERY	4 L/min
MATERIAL OUTLET	M16 x 1,5 (M)
WEIGHT	38 Kg
LEVEL OF THE SOUND PRESSURE	≤ 65dB(A)
LENGTH	(A) 1100 mm
WIDTH	(B) 500 mm
MAXIMUM HEIGHT	(C) 1000 mm
MINIMUM HEIGHT	(C1) 710 mm

*Available on request with special voltages

PARTS OF THE PUMP IN CONTACT WITH THE MATERIAL Stainless Steel AISI 420B, Teflon, Aluminium.

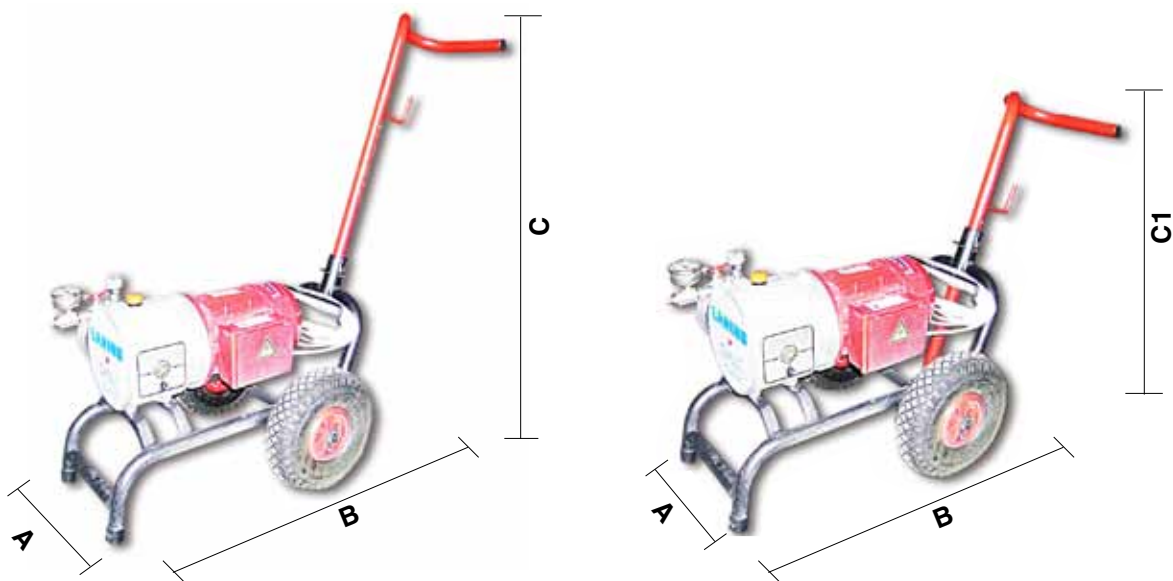

C DESCRIPTION OF THE EQUIPMENT



POS.	Description
1	Carriage
2	Electric / combustion motor
3	High pressure manometer
4	Setting valve
5	Hydraulic oil filling cap
6	Hydraulic body
7	Colour body
8	Suction and recirculation tube
9	High pressure feed tube

POS.	Description
10	LARIUS AT 250 gun
11	Fast clean
12	Tools box
13	Recirculation valve
14	Recirculation pipe connection
15	Feed tube connection
16	Adjustable handle
17	Tank (for "vertical Dalì" version)

D TRANSPORT AND UNPACKING

- The packed parts should be handled as indicated in the symbols and markings on the outside of the packing.
- Before installing the equipment, ensure that the area to be used is large enough for such purposes, is properly lit and has a clean, smooth floor surface.
- The user is responsible for the operations of unloading and handling and should use the maximum care so as not to damage the individual parts or injure anyone. To perform the unloading operation, use only qualified and trained personnel (truck and crane operators, etc.) and also suitable hoisting equipment for the weight of the installation or its parts. Follow carefully all the safety rules. The personnel must be equipped with the necessary safety clothing.
- The manufacturer will not be responsible for the unloading operations and transport to the workplace of the machine.
- Check the packing is undamaged on receipt of the equipment. Unpack the machine and verify if there has been any damage due to transportation. In case of damage, call immediately LARIUS and the Shipping Agent. All the notices about possible damage or anomalies must arrive timely within 8 days at least from the date of receipt of the plant through Registered Letter to the Shipping Agent and to LARIUS.
- The disposal of packaging materials is a customer's competence and must be performed in accordance with the regulations in force in the country where the plant is installed and used. It is nevertheless sound practice to recycle packaging materials in an environment-friendly manner as much as possible.

E SAFETY RULES

- THE EMPLOYER SHALL TRAIN ITS EMPLOYEES ABOUT ALL THOSE RISKS STEMMING FROM ACCIDENTS, ABOUT THE USE OF SAFETY DEVICES FOR THEIR OWN SAFETY AND ABOUT THE GENERAL RULES FOR ACCIDENT PREVENTION IN COMPLIANCE WITH INTERNATIONAL REGULATIONS AND WITH THE LAWS OF THE COUNTRY WHERE THE PLANT IS USED.

THE BEHAVIOUR OF THE EMPLOYEES SHALL STRICTLY COMPLY WITH THE ACCIDENT PREVENTION AND ALSO ENVIRONMENTAL REGULATIONS IN FORCE IN THE COUNTRY WHERE THE PLANT IS INSTALLED AND USED.



Read carefully and entirely the following instructions before using the product. Please save these instructions in a safe place.



The unauthorised tampering/replacement of one or more parts composing the machine, the use of accessories, tools, expendable materials other than those recommended by

the Manufacturer can be a danger of accident.

The Manufacturer will be relieved from tort and criminal liability.

- KEEP YOUR WORK PLACE CLEAN AND TIDY. DISORDER WHERE YOU ARE WORKING CREATES A POTENTIAL RISK OF ACCIDENTS.
- ALWAYS KEEP PROPER BALANCE AVOIDING UNUSUAL STANCE.
- BEFORE USING THE TOOL, ENSURE THERE ARE NOT DAMAGED PARTS AND THE MACHINE CAN WORK PROPERLY.
- ALWAYS FOLLOW THE INSTRUCTIONS ABOUT SAFETY AND THE REGULATIONS IN FORCE.
- KEEP THOSE WHO ARE NOT RESPONSIBLE FOR THE EQUIPMENT OUT OF THE WORK AREA.
- **NEVER** EXCEED THE MAXIMUM WORKING PRESSURE INDICATED.
- **NEVER** POINT THE SPRAY GUN AT YOURSELVES OR AT OTHER PEOPLE. THE CONTACT WITH THE CASTING CAN CAUSE SERIOUS INJURIES.
- IN CASE OF INJURIES CAUSED BY THE GUN CASTING, SEEK IMMEDIATE MEDICAL ADVICE SPECIFYING THE TYPE OF THE PRODUCT INJECTED. **NEVER** UNDERVALUE A WOUND CAUSED BY THE INJECTION OF A FLUID.
- ALWAYS DISCONNECT THE SUPPLY AND RELEASE THE PRESSURE IN THE CIRCUIT BEFORE PERFORMING ANY CHECK OR PART REPLACEMENT OF THE EQUIPMENT.
- NEVER MODIFY ANY PART IN THE EQUIPMENT. CHECK REGULARLY THE COMPONENTS OF THE SYSTEM. REPLACE THE PARTS DAMAGED OR WORN.
- TIGHTEN AND CHECK ALL THE FITTINGS FOR

CONNECTION BETWEEN PUMP, FLEXIBLE HOSE AND SPRAY GUN BEFORE USING THE EQUIPMENT.

- ALWAYS USE THE FLEXIBLE HOSE SUPPLIED WITH STANDARD KIT. THE USE OF ANY ACCESSORIES OR TOOLING OTHER THAN THOSE RECOMMENDED IN THIS MANUAL, MAY CAUSE DAMAGE OR INJURE THE OPERATOR.
- THE FLUID CONTAINED IN THE FLEXIBLE HOSE CAN BE VERY DANGEROUS. HANDLE THE FLEXIBLE HOSE CAREFULLY. DO NOT PULL THE FLEXIBLE HOSE TO MOVE THE EQUIPMENT. NEVER USE A DAMAGED OR A REPAIRED FLEXIBLE HOSE.

The high speed of travel of the product in the hose can create static electricity through discharges and sparks. It is suggested to earth the equipment.



The pump is earthed through the earth cable of the supply.

The gun is earthed through the high pressure flexible hose. All the conductors near the work area must be earthed.

- NEVER SPRAY OVER FLAMMABLE PRODUCTS OR SOLVENTS IN CLOSED PLACES.
- NEVER USE THE TOOLING IN PRESENCE OF POTENTIALLY EXPLOSIVE GAS.

Always check the product is compatible with the materials composing the equipment (pump, spray gun, flexible hose and accessories) with which it can come into contact. Never use paints or solvents containing Halogen Hydrocarbons (as the Methylene Chloride).



If these products come into contact with aluminium parts can provoke dangerous chemical reactions with risk of corrosion and explosion.



IF THE PRODUCT TO BE USED IS TOXIC, AVOID INHALATION AND CONTACT BY USING PROTECTION GLOVES, GOGGLES AND PROPER FACE SHIELDS.



TAKE PROPER SAFETY MEASURES FOR THE PROTECTION OF HEARING IN CASE OF WORK NEAR THE PLANT.

Electrical safety precautions

- Check the "ON/OFF" switch is on the "OFF" position before connecting the cable to the mains.
- Never carry a plugged-in equipment.
- Disconnect the equipment before storing it and before performing any maintenance operation or replacing of accessories.
- Do not carry the equipment neither unplug it by pulling the electric cable. Protect the cable from heat, oil and sharp edges.
- When the tool is used outdoors, use only an extension cable suited for outdoor use and so marked.



Never attempt to tamper with the calibre of instruments.

- Take care when the pumping rod is moving. Stop the machine whenever someone is within its vicinity.
- Repairs of the electrical equipment should only be carried out by skilled personnel, otherwise considerable danger to the user may result.

F SETTING-UP

CONNECTION OF THE FLEXIBLE HOSE TO THE GUN

- Connect the high pressure flexible hose to the pump and to the gun, ensuring to tighten the fittings (*the use of two wrenches is suggested*). **NEVER** use sealants on fittings' threads.
- It is recommended to use the hose provided with the standard kit (*ref. 35017*). **NEVER** use a damaged or a repaired flexible hose.

CHECK ON POWER SUPPLY

- Check the plant is earthed.

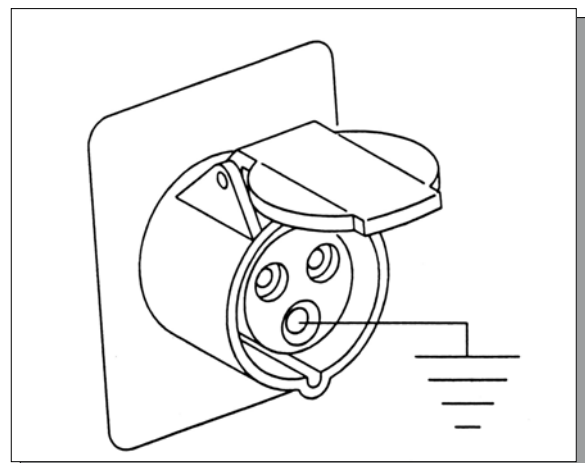

- Check the mains voltage corresponds to the equipment's rating (**F1**).



- The supply cable (**F2**) is provided without plug. Use a plug which guarantees the plant earthing. Only a technician or a skilled person should perform the connection of the plug to the electric cable.

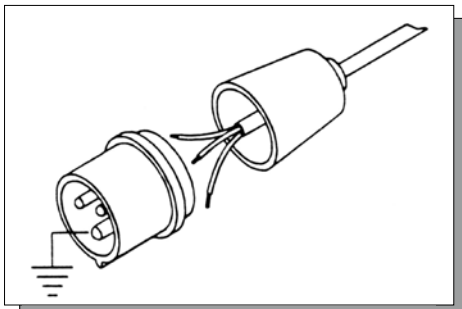
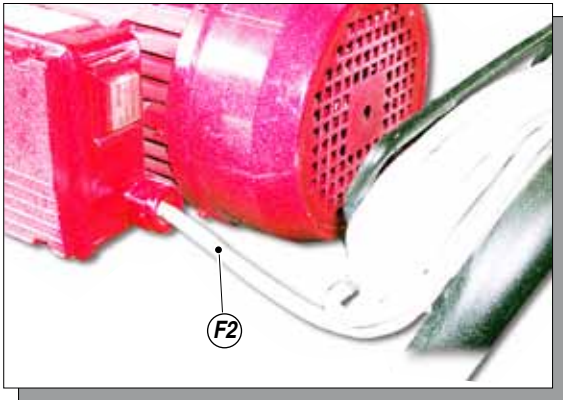

Should anyone use an extension cable between the tooling and the socket, it must have the same characteristics as the cable supplied (minimum diameter of the wire 2.5 mm²) with a maximum length of 50 mt. Higher lengths and lower diameters can provoke excessive voltage falls and also an anomalous working of the equipment.



CONNECTION OF THE TOOLING TO THE POWER SUPPLY

- Check the ON/OFF switch (**F3**) is on the "OFF" position (0) before connecting the cable to the mains.
- Place the pressure control knob (**F4**) on the "MIN" position (turn counterclockwise).

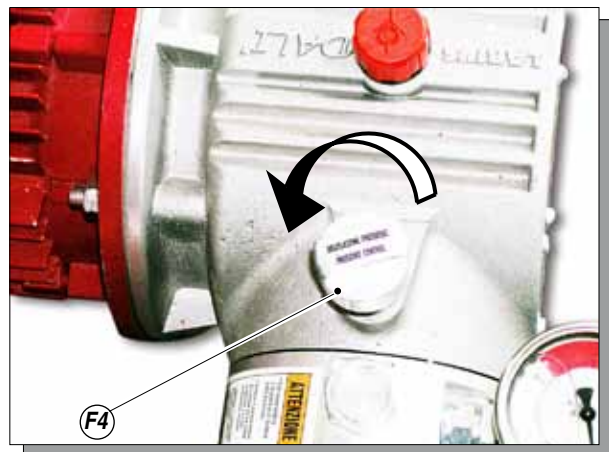

WASHING OF THE NEW EQUIPMENT

- The equipment has already been adjusted at our factory with light mineral oil left inside the pumping group as protection. Therefore, wash with diluent before sucking the product.

- Lift the suction pipe and dip it into the solvent tank (F5).
- Ensure the gun (F6) is without nozzle.

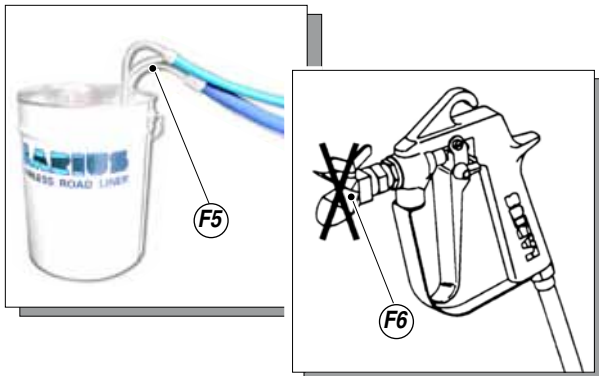

- Open the re-circulation tap (F7).
Turn the unit ON-OFF switch (F8) on the "ON" position (I).

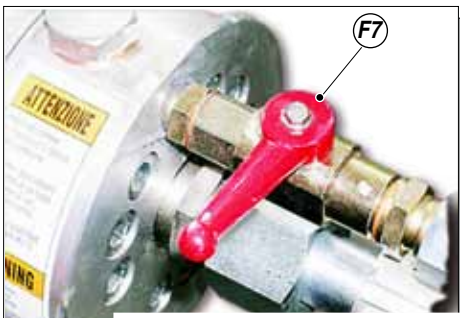

- Rotate the pressure setting knob (F9) slightly clockwise so that the machine operates at minimum power.

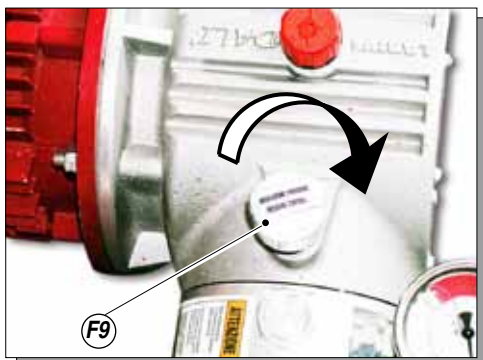

- Point the gun at a container keeping the trigger pressed (so as to drain the oil inside) till a clean solvent comes out. Now, release the trigger.
- Remove the suction pipe and take away the solvent tank.
- Point the gun at the solvent tank and press the trigger so as to recover the residual solvent.
- As the pump idles, press the ON/OFF switch (F8) on the position "OFF" (0) to stop the tooling.



Absolutely avoid to spray solvents indoors. In addition, it is recommended to keep away from the pump in order to avoid the contact between the solvent fumes and the electric motor.

- Now the machine is ready. Should you use water paints, besides the solvent wash, a wash with soapy and then clean water is suggested.
- Insert the gun trigger lock and assemble the nozzle.

PREPARATION OF THE PAINT

- Make sure the product is suitable to be used with a spray gun.
- Mix and filter the product before using it. For filtration, use **CLOSE-MESH (ref.214)** and **LARGE-MESH (ref.215) LARIUS METEX** braids.



Make sure the product to be used is compatible with the materials employed for manufacturing the equipment (stainless steel and aluminium). Because of that, please contact the supplier of the product.

Never use products containing halogen hydrocarbons (as *methylene chloride*). If these products come into contact with aluminium parts of the equipment, can provoke dangerous chemical reactions with risk of explosion.

G WORKING

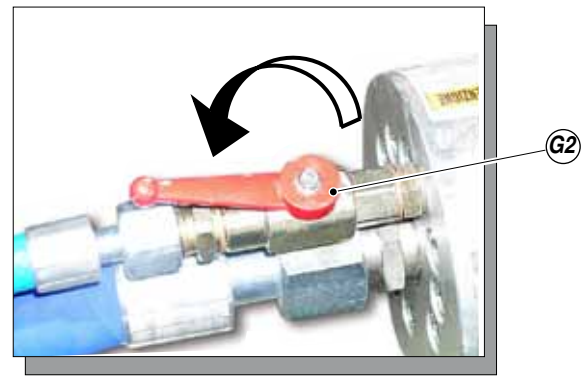

START OF THE PAINTING OPERATIONS

- Use the tooling after performing all the **SETTING UP** operations above described.
- Dip the suction pipe (**G1**) into the product tank.
- Open the re-circulation valve (**G2**).
- Press the **ON/OFF** switch of the equipment and turn a little the pressure control knob (**G3**) clockwise, so as the machine works at the idle speed.
- Make sure the product recycles from the return tube (**G4**).
- Close the re-circulation valve.
- At this point the machine will continue to suck the paint product until the delivery hose is completely full. Afterwards, the product will re-circulate automatically.

SPRAY ADJUSTMENT

- Slowly turn clockwise the pressure control knob to reach the pressure value in order to ensure a good atomization of the product.
- An irregular and marked spray on the sides indicates a low working pressure. On the contrary, a too high pressure causes a high fog (*"overspray"*) and waste of product.
- In order to avoid overthickness of paint, let the gun advance sideways (*right-left*) when spraying.
- Always paint with regular parallel bands coats.
- Keep a safety and constant distance between the gun and the support to be painted and also keep yourselves perpendicular to it.



NEVER point the spray gun at yourselves or at other people. The contact with the casting can use serious injuries. In case of injuries caused by the gun casting, seek immediate medical advice specifying the type of the product injected.



The drain valve is a safety valve too. When working at the maximum pressure available, releasing the gun trigger sudden increases of pressure can occur. In this case, the drain valve opens automatically eliminating part of the product from the recirculating tube. Then it closes so as to go back to the first working conditions.

H CLEANING AT THE END WORK

- Reduce pressure to the minimum (turn counterclockwise the pressure control knob (H1)).



- Press the ON/OFF switch (H2) placed on the box of the electric motor, to stop the equipment.
- Make sure the solvent recycles the washing fluid from the return tube (H4).
- First release the residual pressure from the gun by holding it pointed down towards the paint container, then open the re-circulation valve (H3).

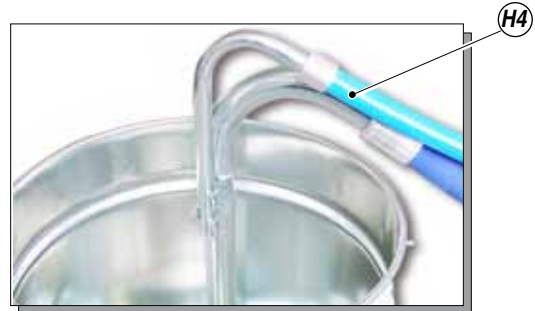
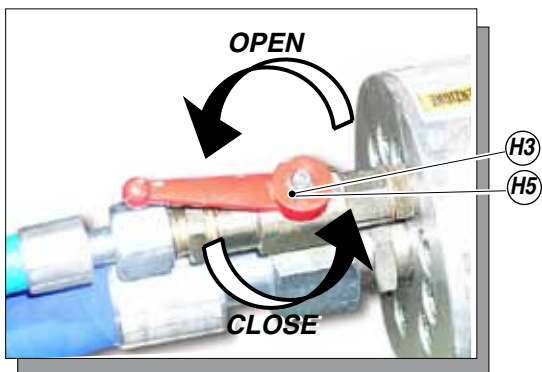

- Close the re-circulation valve (H5).
- Point the gun at the product tank and, keeping the trigger pressed, release the remaining product till a clean solvent comes out. Now, release the trigger.
- Lift again the suction pipe and remove the solvent tank.
- Now point the gun at the solvent tank and press the trigger so as to recover the residual solvent.
- As the pump starts idling, press the ON/OFF switch to stop the equipment.
- In case of long storage, we recommend you to suck and to leave light mineral oil inside the pumping group and the flexible hose.
- Lift the suction pipe and replace the product tank with that of the solvent (ensure it is compatible with the product being used).
- Unscrew the gun nozzle (do not forget to clean it with solvent!).
- Turn the ON-OFF switch (H2) on the ON position and rotate the pressure setting knob (H1) slightly clockwise.



Follow the washing procedure before using again the equipment.

I ROUTINE MAINTENANCE

TOP UP HYDRAULIC OIL

With each start up, check the hydraulic oil level by looking through the gauge (11) on the side of the hydraulic body. If necessary, use “AGIP OSO 46 type hydraulic oil” to top up the level.



(11)

RELEASE THE SUCTION VALVE

If the pump malfunctions, release the suction valve fitted on the head of the pump in the following way:

- Remove the suction hose fitting and release the valve by inserting a rigid rod (12) with a diameter of no more than 15 mm.

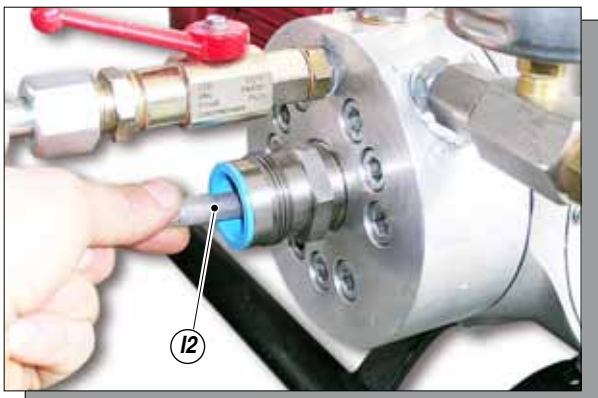

(12)

CLEANING THE COMPRESSION VALVE

When the compression valve (13) must be removed, clean it with specific solvents depending on the type of paint used and refit all parts by inverting the removal order.

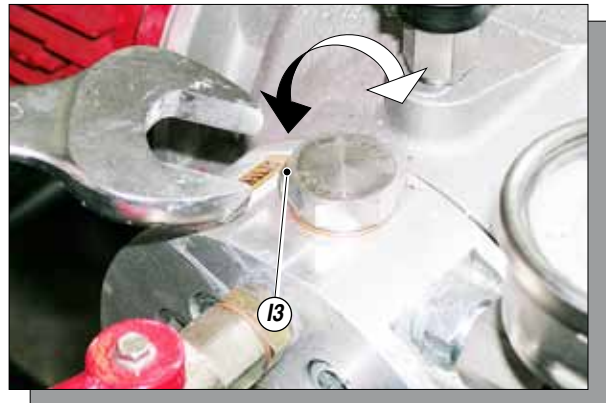

(13)



Assemble the components in the correct order.

REPLACING HYDRAULIC OIL

After operating for 100 hours, replace the oil in the pump;

- Discharge the waste oil through the **plug (14)** fitted at the bottom of the pump casing.
- Clean the seals on the cap and replace it if worn.
- Remove and clean the filter (15) on the side of the pump casing; if necessary, replace the filter and the respective seals.
- Clean and, if necessary, replace the worn seals (15).
- Replace the plug (14).
- Fill the pump with the recommended oil until it reaches the maximum level.
- Then, substitute the oil every 250 hours.

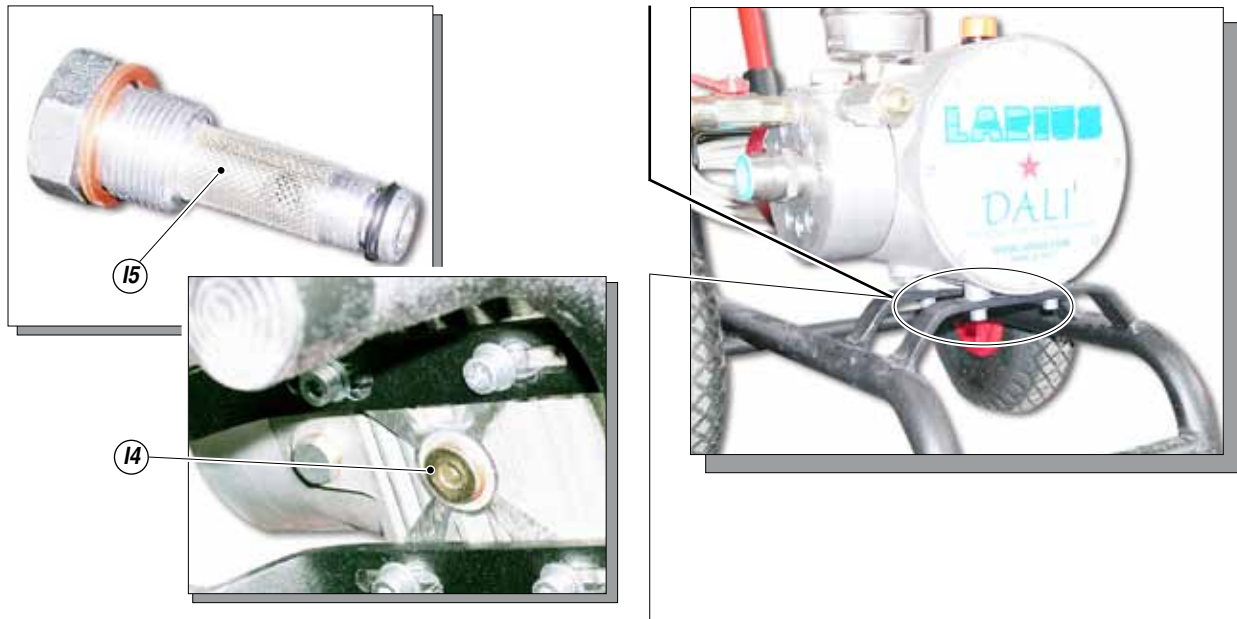

CLEANING THE MOTOR COOLING FAN GUARD

Clean the motor cooling fan protection guard (16) periodically to ensure the best cooling.



L WARNING PLATE

 <i>Apparecchi per verniciatura</i>	 Paint spraying units
 ATTENZIONE UTILIZZARE GRUPPI ELETTROGENI CON ALTERNATORE ASINCRONO	 WARNING USE POWER UNITS WITH ASYNCHRONOUS ALTERNATOR
http: www.larius.com	e-mail larius@larius.com

M PROBLEMS AND SOLUTIONS

Problem	Cause	Solution
<ul style="list-style-type: none"> The equipment does not start 	<ul style="list-style-type: none"> Lack of voltage; Considerable drops in mains voltage; ON-OFF switch disconnected; Setting valve faulty pressure; Breakdown of motor electric control box; The product is solidified inside the pump; 	<ul style="list-style-type: none"> Check the correct connection to the power supply; Check the extension cable; Ensure the ON-OFF switch is on the "ON" position and turn clockwise the pressure control knob; Verify and replace it, if necessary; Verify and replace it, if necessary; Open the drain valve to release pressure in the circuit and stop the machine. Remove the compression valve and clean it;
<ul style="list-style-type: none"> The equipment does not suck the product 	<ul style="list-style-type: none"> Suction filter clogged; Suction filter too fine; The equipment sucks air; 	<ul style="list-style-type: none"> Clean or replace it; Replace it with a larger-mesh filter (<i>with very dense products, remove the filter</i>); Check the suction pipe;
<ul style="list-style-type: none"> The equipment suck but does not reach the pressure desired 	<ul style="list-style-type: none"> Lack of product; The equipment sucks air; The drain valve is open; Suction or delivery valve dirty; 	<ul style="list-style-type: none"> Add the product; Check the suction pipe; Close the drain valve; Disassemble the colour body group;
<ul style="list-style-type: none"> When pressing the trigger, the pressure lowers considerably 	<ul style="list-style-type: none"> Nozzle too big or worn; The product is too dense; The filter of the gun-butt is too fine; 	<ul style="list-style-type: none"> Replace it with a smaller one; Dilute the product, if possible; Replace it with a larger-mesh filter;
<ul style="list-style-type: none"> The pressure is normal but the product is not atomized. Leakage from the seal-tightening screw 	<ul style="list-style-type: none"> The nozzle is partially clogged; The product is too dense; The filter of the gun-butt is too fine; 	<ul style="list-style-type: none"> Clean or replace it; Dilute the product, if possible; Replace it with a larger-mesh filter;
<ul style="list-style-type: none"> The atomization is imperfect 	<ul style="list-style-type: none"> The nozzle is worn; 	<ul style="list-style-type: none"> Replace it;



Always close the air compressed supply and unload the plant pressure before performing any check or replacement of pump parts (see "correct procedure of decompression").

N CORRECT PROCEDURE OF DECOMPRESSION

- Insert the gun clamp (N1).
- Move the ON/OFF switch (N2) to the OFF position (0) to stop the equipment.
- Set the valve (N3) at its minimum pressure setting (turn anticlockwise).

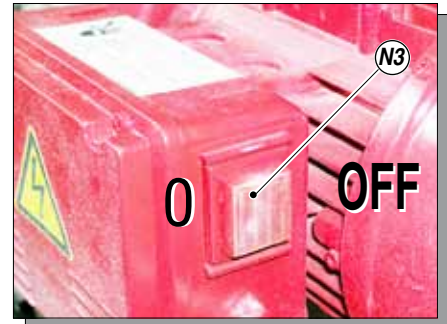
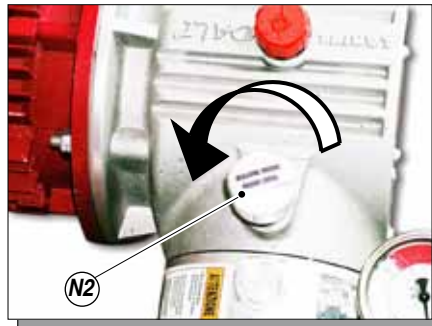
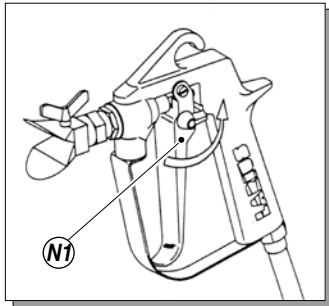

- Disconnect the power supply cable (N4).

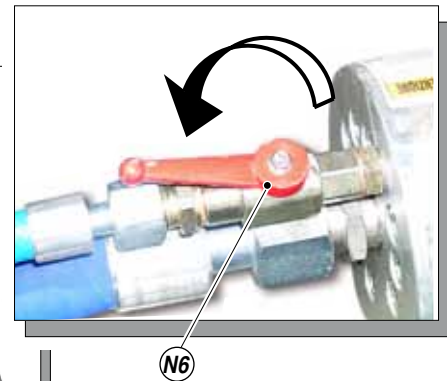
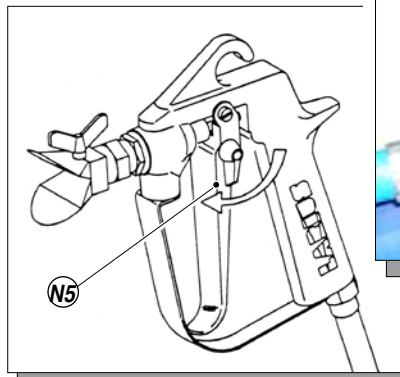
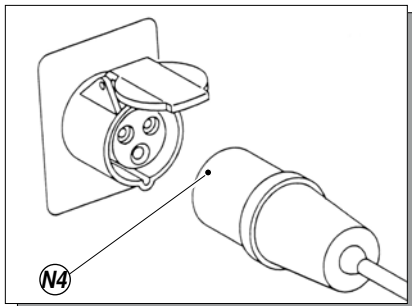

- Release the gun clamp (N5). Point the gun at the tank of the product and press the trigger to release pressure. At the end of the operation, insert the gun clamp.
- Open the re-circulation valve (N6) to release residual pressure.



WARNING :

If the equipment is still under pressure after performing the operations above described because of the nozzle or the flexible hose clogged, proceed as follows:

- Loosen very slowly the gun nozzle.
- Release the clamp.
- Point the gun at the container of the product and press the trigger to release pressure.
- Loosen very slowly the fitting of connection from the flexible hose to the gun.
- Clean or replace the flexible hose and the nozzle.

0 COMPLETE HYDRAULIC BODY

English

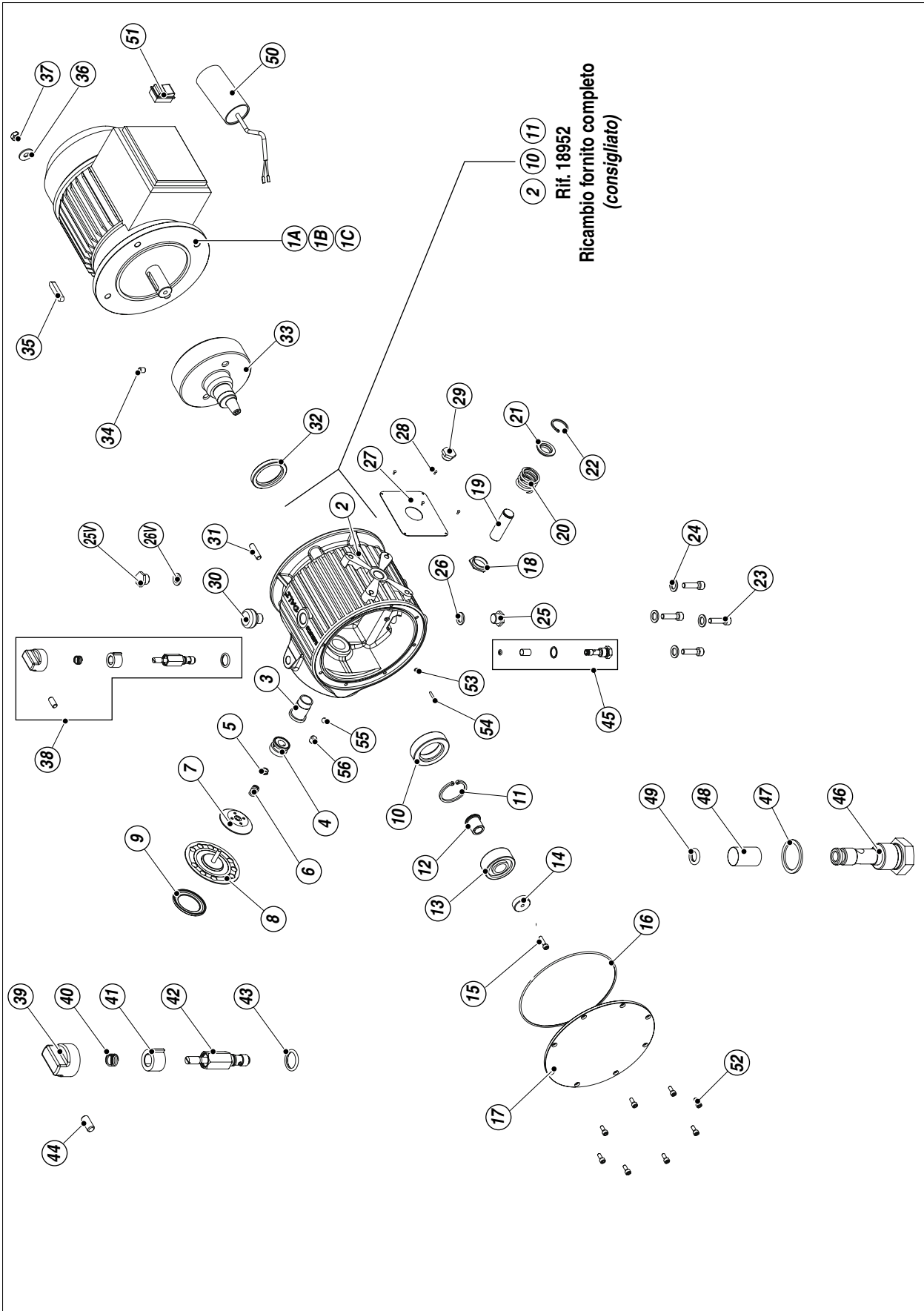

Pos.	Code	Description	Pos.	Code	Description
1A	18925	Electric motor mono-phase 220V 50Hz complete	27	18931	Identification plate 110V 60Hz
1B	18926	Electric motor mono-phase 110V 60Hz complete	27	18932	Petrol identification plate
1C	18924	Electric motor three-phases 380V 50Hz complete	27	18933	Identification plate 380V 50Hz
2**	18901	Hydraulic body	28	34020	Rivet
3**	32018	Cylinder liner	29	32007	Oil inspection window
4	32033	Piston insert	30	32108	Plug
5**	91026	Nut	31	81012	Spline
6**	33002/3	Spring	32	18909	Corteco
7**	18937	Oil distributor	33	18947	Eccentric flywheel
8**	33002/1	Diaphragm	34	81009	Dowel
9	18936	Diaphragm insert	35	18919	Tab
10**	31125	Bearing	36	33005	Washer
11**	81020	Elastic ring	37	18903	Nut
12	18906	Bushing	38	32150	Complete pressure regulation valve
13	32026	Bearing	39	32017	Knob
14	32027	Cover	40	32017/2	Spring
15	32029	Screw	41	32016	Retainer
16	18908	OR	42	32155	Valve body
17	18907	Cover	43	32014	OR
18**	32041	Check nut	44	32017/1C	Dowel
19	32019	Piston	45	12475	Oil filter assembly
20	32022	Spring	46	12461	Filter
21	32021	Spring cap	47	32010	Copper washer
22	32020	Elastic ring	48	258	Filter sieve 60 MESH
23	96031	Screw	49	32012	OR
24	32024	Washer	50	18928	Motor condenser 220V 50Hz
25	32108	Plug	50	18929	Motor condenser 110V 60Hz
25V*	32108	Plug	51	18938	Switch
26	33010	Washer	52	32032	Screw
26V*	33010	Washer	53*	5059	Washer
27	18910	Identification plate 220V 50Hz	54*	18567	Screw
			55*	91915	Ball
			56	18946	Dowel

* Only in the vertical configuration

**Pos. 2-3-10-11-18 spare supplied complete (*recommended*) - Ref. 18952

**Pos. 5-6-7-8 complete diaphragm - Ref. 18904

P DALÌ PETROL - DALÌ LINER

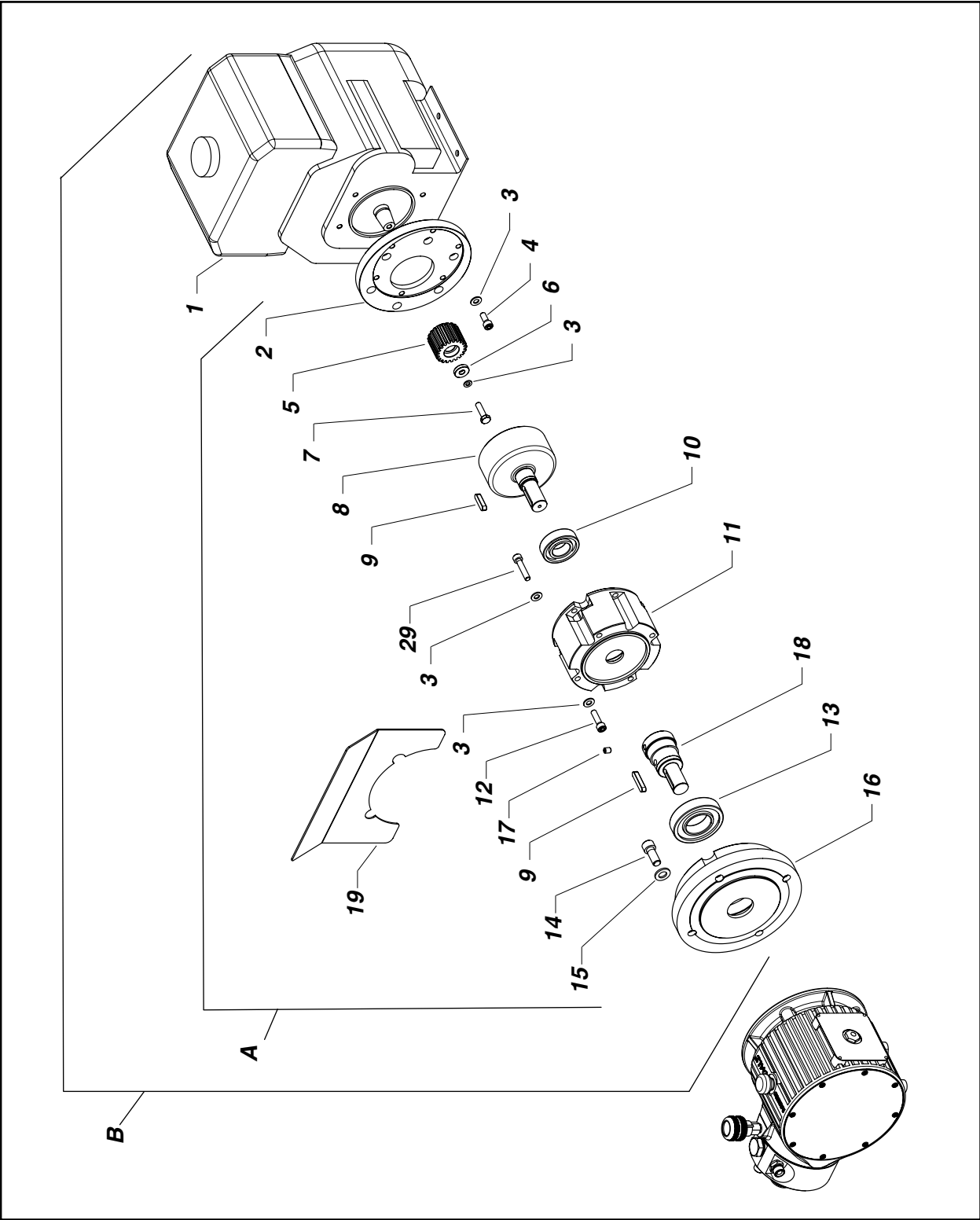

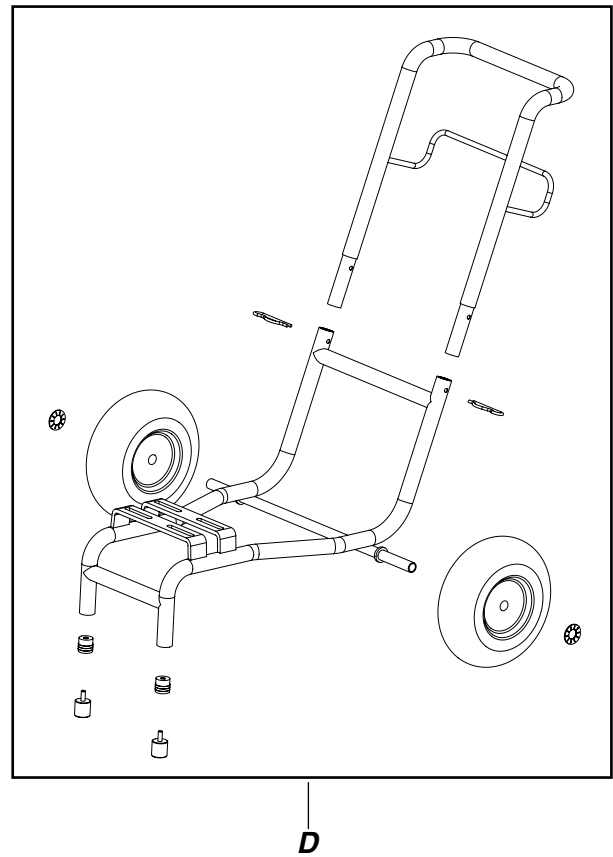
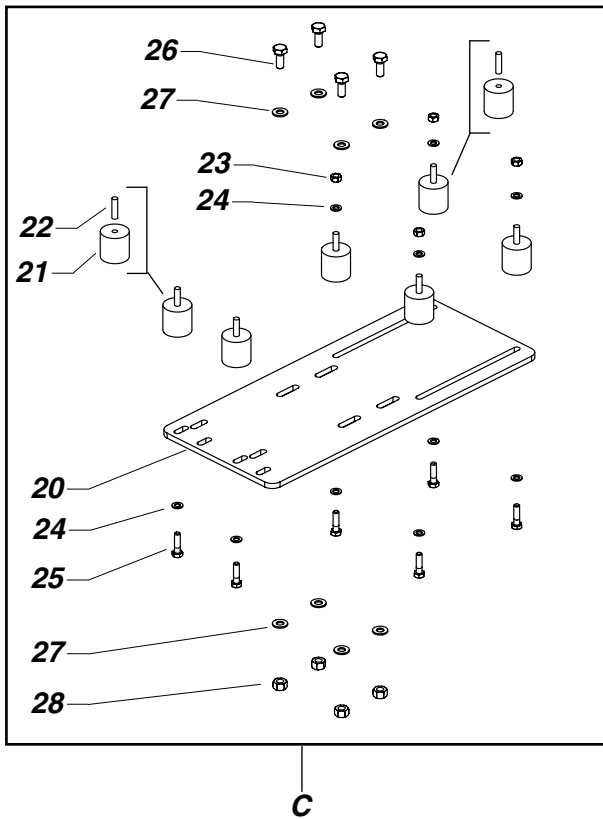

Pos.	Code	Description	Pos.	Code	Description
A	18260	Complete gearbox – petrol membrane version	13	18267	Bearing
B+C+D	18340	Complete gearbox kit – Dalì petrol version with trolley	14	18344	Screw
B+C	18347	Complete Dalì liner kit	15	95114	Washer
1	4415	Motor	16	18268	Hydraulic flange
2	18261	Flange motor	17	81009	Dowel
3	34009	Washer	18	18269	Reduction
4	96031	Screw	19	18264	Plating guard
5	18262	Pinion	20	18254	Fixing plate
6	18263	Washer	21	81107	Vibration damper
7	8385	Screw	22	18942	Threaded pin
8	18265	Toothed bell	23	52017	Nut
9	18919	Tab	24	32024	Washer
10	42255	Bearing	25	34008	Screw
11	18266	Gearbox cone	26	95156	Screw
12	34008	Screw	27	81033	Washer
			28	95158	Nut
			29	7059	Screw

Q COMPLETE COLOUR BODY

VERTICAL VERSION

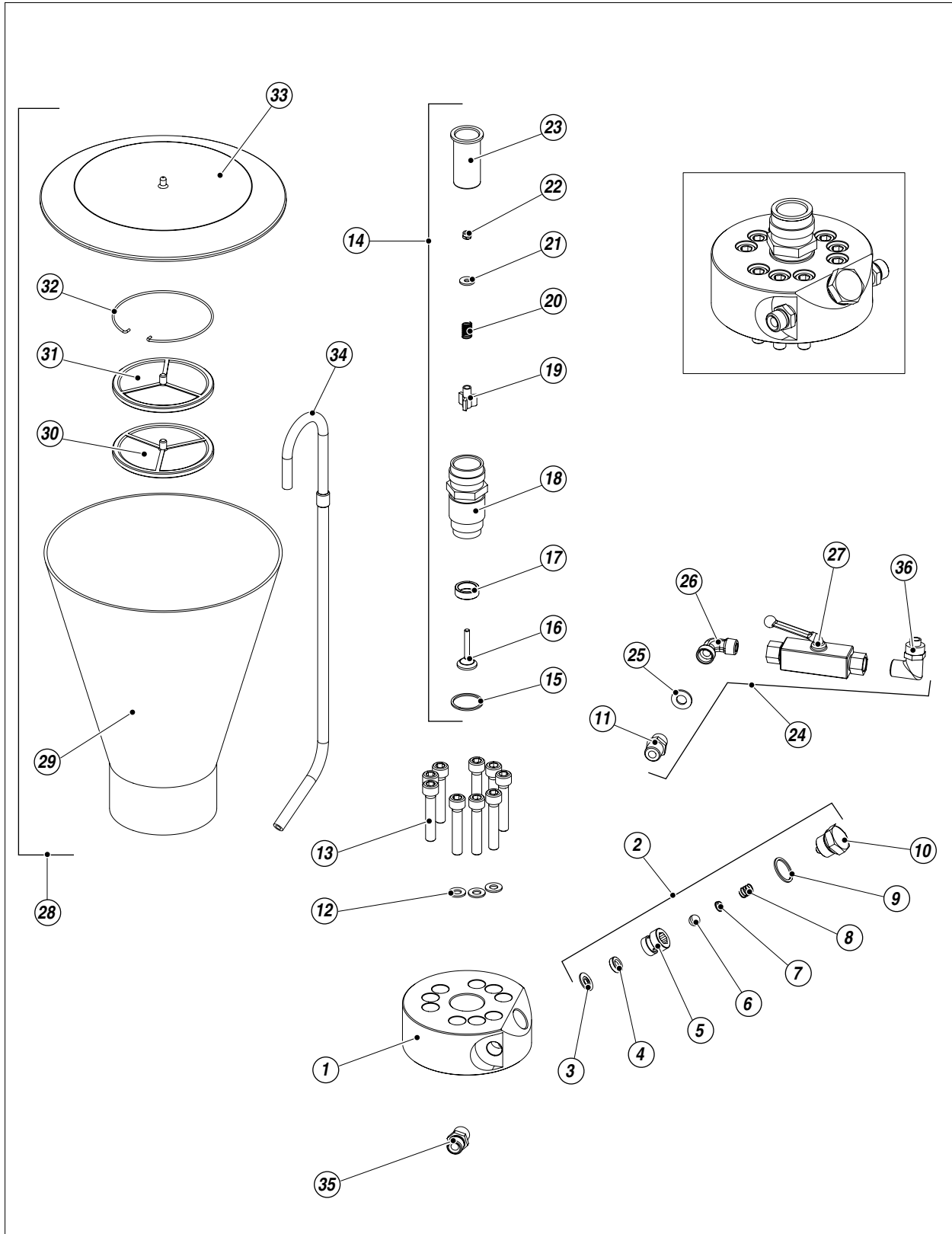

Pos.	Code	Description	Pos.	Code	Description
1	18951	Vertical colour body	19	33021	Shutter guide
2	33033	Valve assembly	20	33022	Spring
3	33026	Gasket	21	33023	Washer
4	33027/2	Ball seat	22	33024	Nut
5	33027/1	Valve housing	23	33025	Seal sleeve
6	33028	Ball	24	18922	Recirculation valve assembly
7	33029	Spring seat	25	33012	Washer
8	53006	Spring	26	18614	Elbow
9	53006/1	Gas-ring	27	33013	Cock
10	33032	Check nut	28	35101	Tank assembly
11	33011	Union	29	35103	Tank
12	33005	Washer	30	35006	Close filter
13	33004	Screw	31	35007	Large filter
14	33017	Complete valve body	32	35008	Spring ring
15	33018	Gas-ring	33	55000	Cover
16	33019	Conical shutter	34	18569	Recirculation tube
17	33020/1	Spear valve seat	35	95284	Union
18	33020	Valve body	36	4011	Union

HORIZONTAL VERSION

English

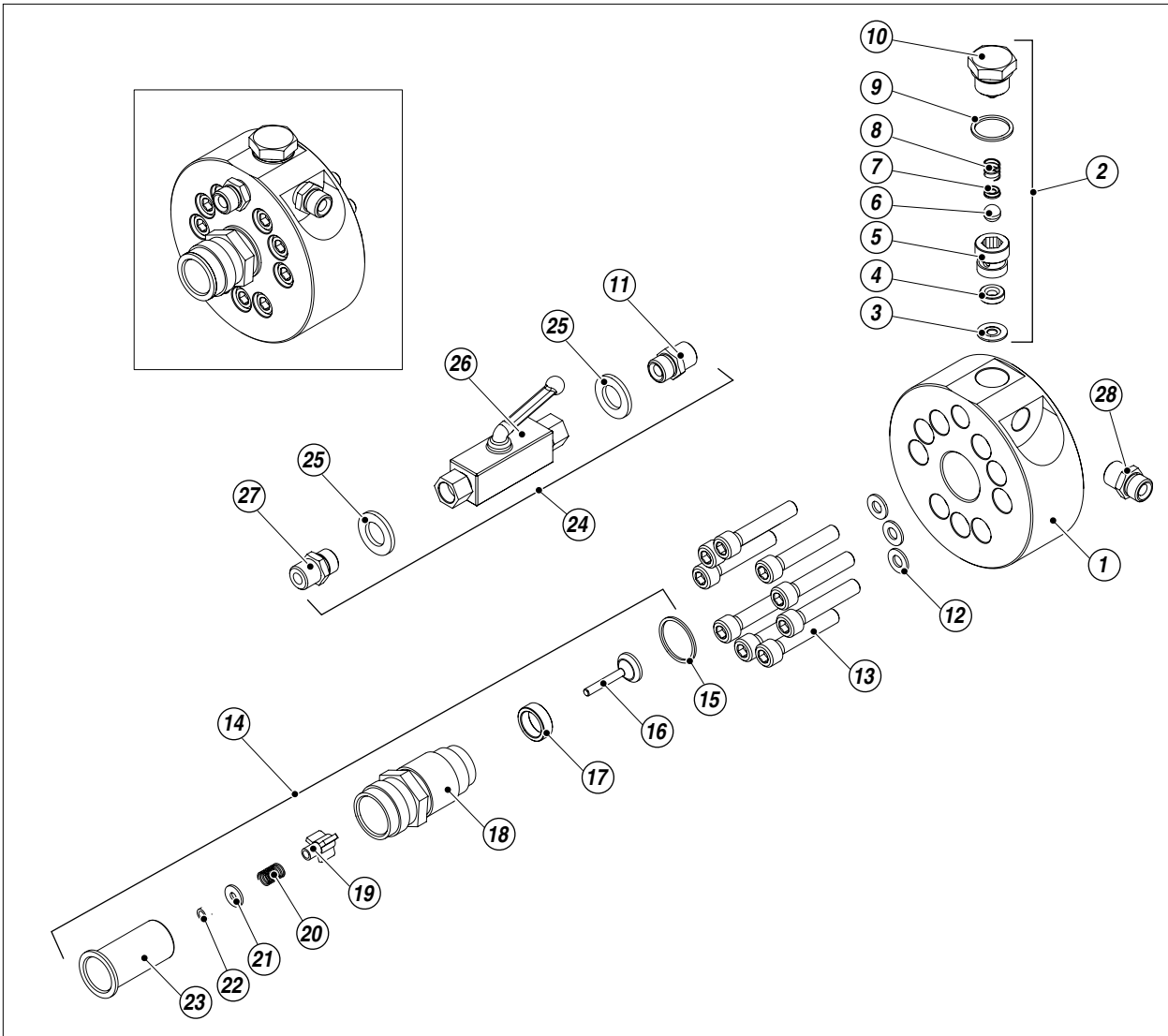

Pos.	Code	Description	Pos.	Code	Description
1	18915	Standard colour body	15	33018	Gas-ring
2	33033	Valve assembly	16	33019	Conical shutter
3	33026	Gasket	17	33020/1	Spear valve seat
4	33027/2	Ball seat	18	33020	Valve body
5	33027/1	Valve housing	19	33021	Shutter guide
6	33028	Ball	20	33022	Spring
7	33029	Spring seat	21	33023	Washer
8	53006	Spring	22	33024	Nut
9	33031	Gas-ring	23	33025	Seal sleeve
10	33032	Plug	24	18922	Recirculation valve assembly
11	33011	Union	25	33012	Washer
12	33005	Washer	26	33013	Cock
13	33004	Screw	27	33015	Union
14	33017	Complete valve body	28	95284	Union

R HIGH PRESSURE GUN "AT 250"

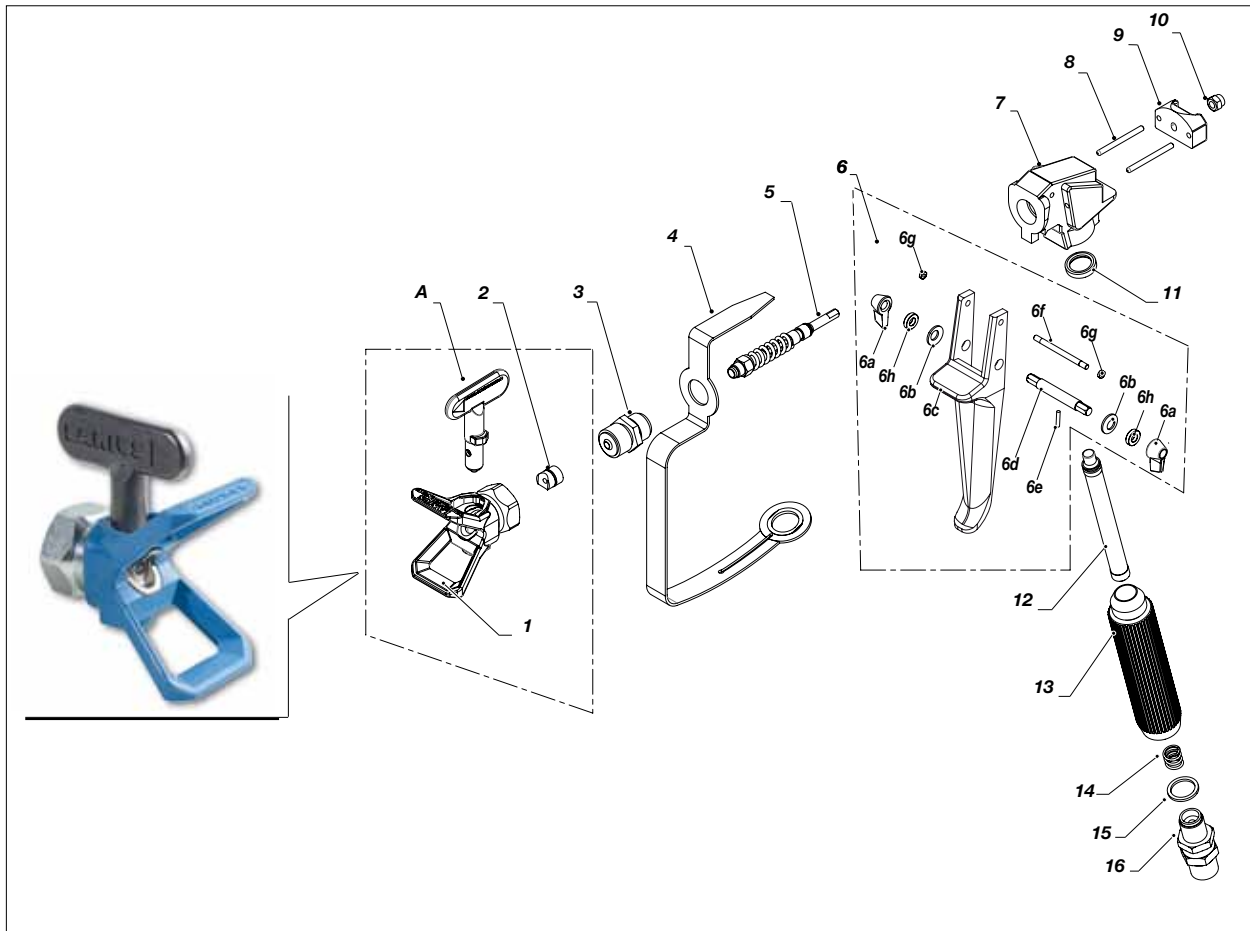

Components Pos. 5 - 11023 - Linkage

11005/3	Ball
11204/1	Ball housing
11205/2	Spring
11205/4	Linkage
11205/5	Sleeve
11205/6	Ring sleeve
11205/7	Bushing

Pos.	Code	Description	Pos.	Code	Description
A	See table*	Nozzle Super Fast Clean	6g	11027	Nut M3
1	18270	Body Super Fast Clean	6h	11016	Washer
2	18280	Gasket Super Fast Clean	7	11206	Gun body
3	11004	Sleeve	8	11207	Spinet
4	11006 + 11032	Safety for hand + 3 screws TSP 3x8	9	11208	Plate
5	11203	Complete linkage	10	11209	Self-locking nut M5
6	11008	Trigger gun	11	11020	Copper gasket
6a	11010	Safety lever	12	-	Filter
6b	11011	Brake washer	13	11018	Handgrip
6c	11009	Trigger	14	11017	Spring
6d	11012	Pin	15	32010	Copper gasket
6e	11013	Pin	16	11015	Articulated joints M16x1,5
6f	11034/1	Pin		11155	Articulated joints 1/4"

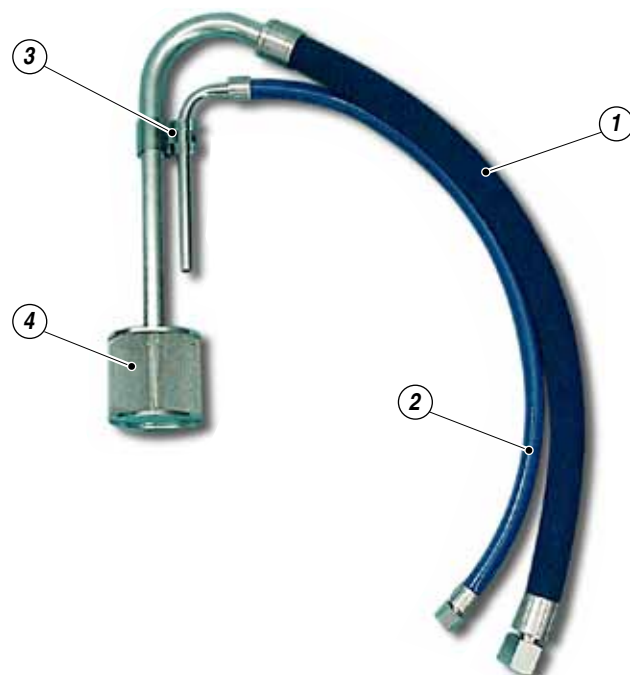
S SUCTION SYSTEMS

Pos.	Code	Description
-	85009	Suction systems
1	85010	Suction tube
2	16609	Recirculation tube
3	18096	Spring
4	85012	Filter of suction

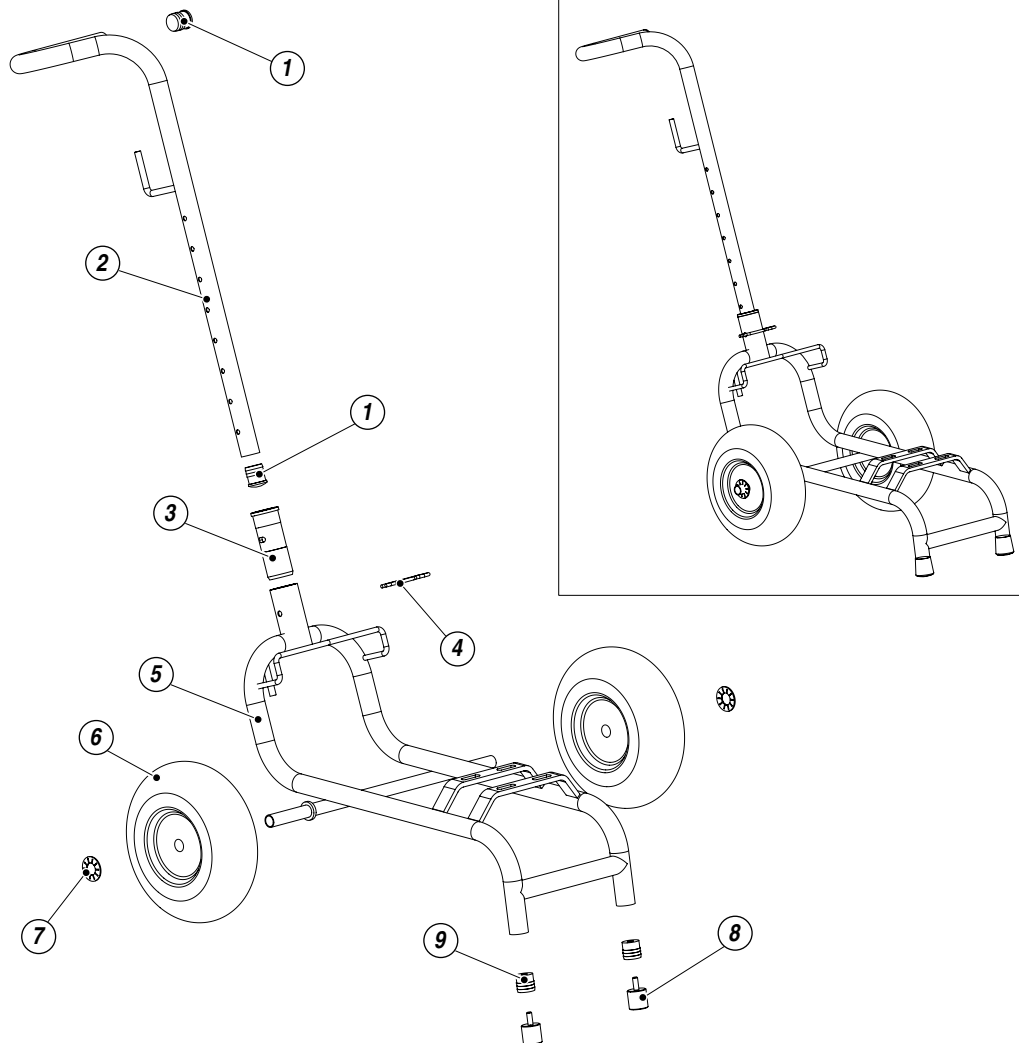
T TROLLEY**ELECTRIC MOTOR**

Pos.	Code	Description
-	18911	Trolley assembly
1	95159	Plug
2	18912	Handle
3	18914	Bushing
4	18902	Split pin
5	18913	Trolley frame
6	37218	Pneumatic wheel
7	91047	Washer
8	12454	Feet
9	12473	Plug

COMBUSTION MOTOR

English

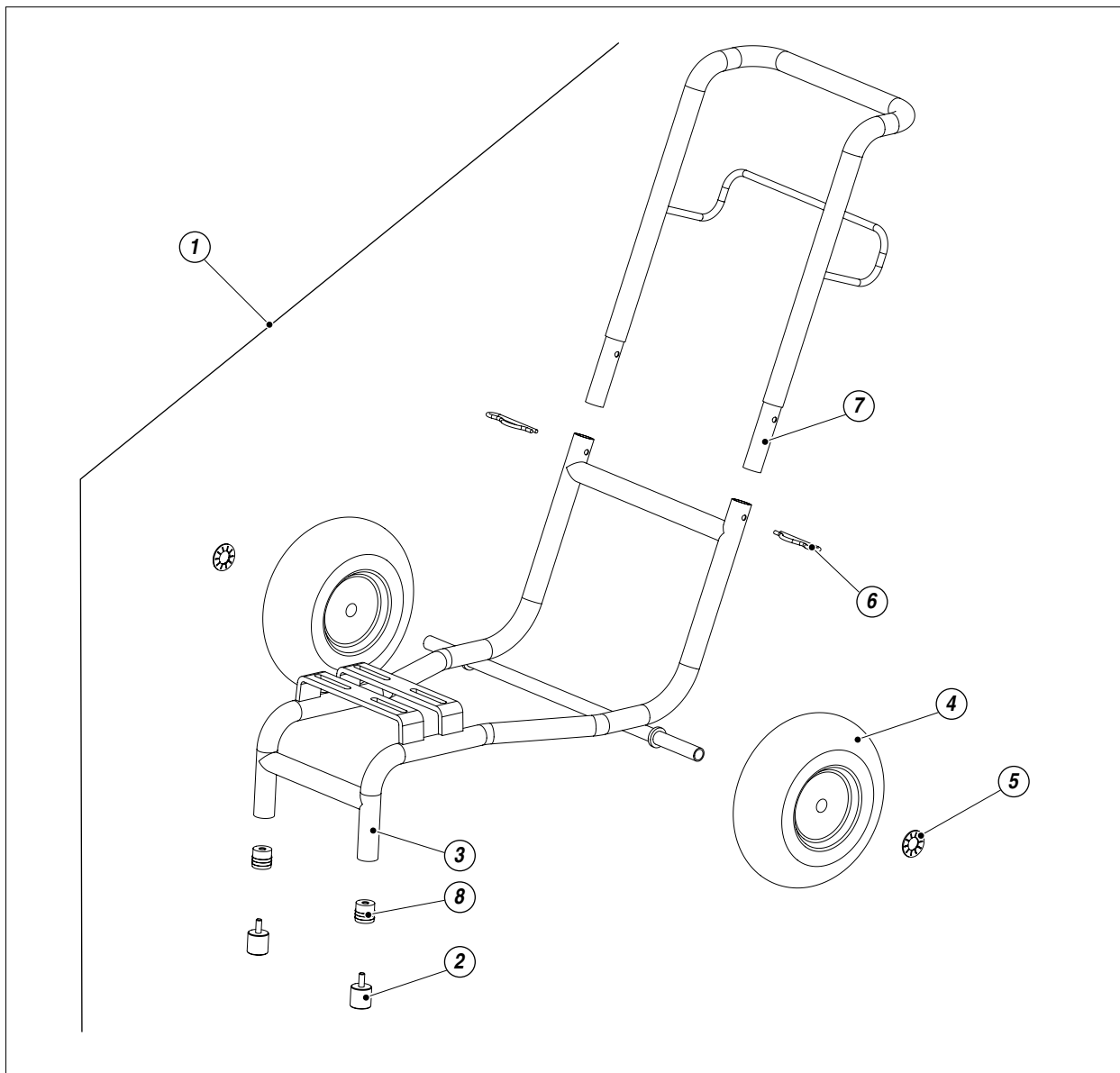

Pos.	Code	Description
1	12355	Trolley assembly
2	12454	Foot
3	12710	Trolley base
4	37218	Pneumatic wheel
5	91047	Elastic washer
6	84007	Split pin
7	12711	Trolley handle
8	12473	Plug

U ACCESSORIES



Art. 11250: AT 250 1/4"
Art. 11200: AT 250 M16x1,5



Code 270: FILTER 100 MESH
Code 271: FILTER 60 MESH



PISTON GUNSTOCK FILTERS
Code 11039: Green (30M) - **Code 11038:** White (60M)
Code 11037: Yellow (100M) - **Code 11019:** Red (200M)



Code 147: HIGH PRESSURE GAUGE M16x1,5
Code 150: HIGH PRESSURE GAUGE GJ 1/4"



Code 85014: FILTER 40 MESH - **Code 85012:** FILTER 20 MESH
Code 37215: FILTER 40 MESH inox - **Code 37216:** FILTER 20 MESH inox



MANUAL GUN LX-T
Code 14310: NOZZLE 4 mm
Code 14311: NOZZLE 6 mm
Code 14312: NOZZLE 8 mm



HIGH PRESSURE HOSE 3/8" - M16x1,5 max pressure 425 bar
Code 18063: 7,5 mt
Code 18064: 10 mt
Code 18065: 15 mt



ANTISTATIC HOSE 3/16" - M16x1,5 max pressure 210 bar
Code 6164: 5 mt
Code 55050: 7,5 mt
Code 35018: 10 mt



ANTIPULSATIONS 1/4" - M16x1,5 max pressure 250 bar
Code 35013: 5 mt
Code 35014: 7,5 mt
Code 35017: 10 mt
Code 18026: 15 mt

SUPER FAST-CLEAN

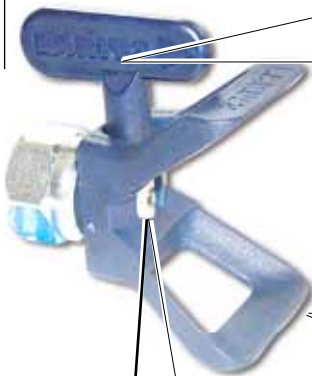

SUPER FAST-CLEAN TIP

Nozzles code		
SFC07-20	SFC19-60	SFC29-80
SFC07-40	SFC21-20	SFC31-40
SFC09-20	SFC21-40	SFC31-60
SFC09-40	SFC21-60	SFC31-80
SFC11-20	SFC23-20	SFC33-40
SFC11-40	SFC23-40	SFC33-60
SFC13-20	SFC23-60	SFC33-80
SFC13-40	SFC25-20	SFC39-40
SFC13-60	SFC25-40	SFC39-60
SFC15-20	SFC25-60	SFC39-80
SFC15-40	SFC27-20	SFC43-40
SFC15-60	SFC27-40	SFC43-60
SFC17-20	SFC27-60	SFC43-80
SFC17-40	SFC27-80	SFC51-40
SFC17-60	SFC29-20	SFC51-60
SFC19-20	SFC29-40	SFC51-80
SFC19-40	SFC29-60	



Code 18280: GASKET



Code 18270: SUPER FAST-CLEAN base UE 11/16x16



GUN EXTENSION
Art. 153: cm 30 - **Art. 153:** cm 40
Art. 155: cm 60 - **Art. 158:** cm 80 - **Art. 156:** cm 100



PLA 1/4"
 + BASE SUPER
 FAST-CLEAN
Art. K11420-K11425-K11430: cm 130-180-240

PLA M16x1,5
 + BASE SUPER
 FAST-CLEAN
Art. K11421-K11426-K11431: cm 130-180-240



Art. 16780: TELESCOPIC PAINT ROLLER

- complete with:
- n. 1 Roller with extra-long fiber
 - n. 1 Roller with long fiber
 - n. 1 Roller with medium fiber
- Flexible hose mt. 2 3/16 " M16x1,5



MX 750

MX 1000 E

MX 1100 E

Code 217550: MX 750 - **Code 217560:** MX 1000 E - **Code 217570:** MX 1100 E



Code 18241: GRAVITY HOPPER 50 lt

DALI VERSIONS

**HORIZONTAL WITHOUT ACCESSORIES**

Ref. 18900: 220V / 50 Hz

Ref. 18920: 110V / 60 Hz

Ref. 18955: 380V / 50 Hz

Ref. 18956: Petrol

HORIZONTAL WITH ACCESSORIES

Ref. 18957: 220V / 50 Hz

Ref. 18958: 110V / 60 Hz

Ref. 18959: 380V / 50 Hz

Ref. 18960: Petrol

**VERTICAL WITHOUT ACCESSORIES**

Ref. 18961: 220V / 50 Hz

Ref. 18962: 110V / 60 Hz

Ref. 18963: 380V / 50 Hz

Ref. 18964: Petrol

VERTICAL WITH ACCESSORIES

Ref. 18965: 220V / 50 Hz

Ref. 18966: 110V / 60 Hz

Ref. 18967: 380V / 50 Hz

Ref. 18968: Petrol

LARIUS

PAINT SPRAYING EQUIPMENT

*L'innovazione.
Quella vera.*

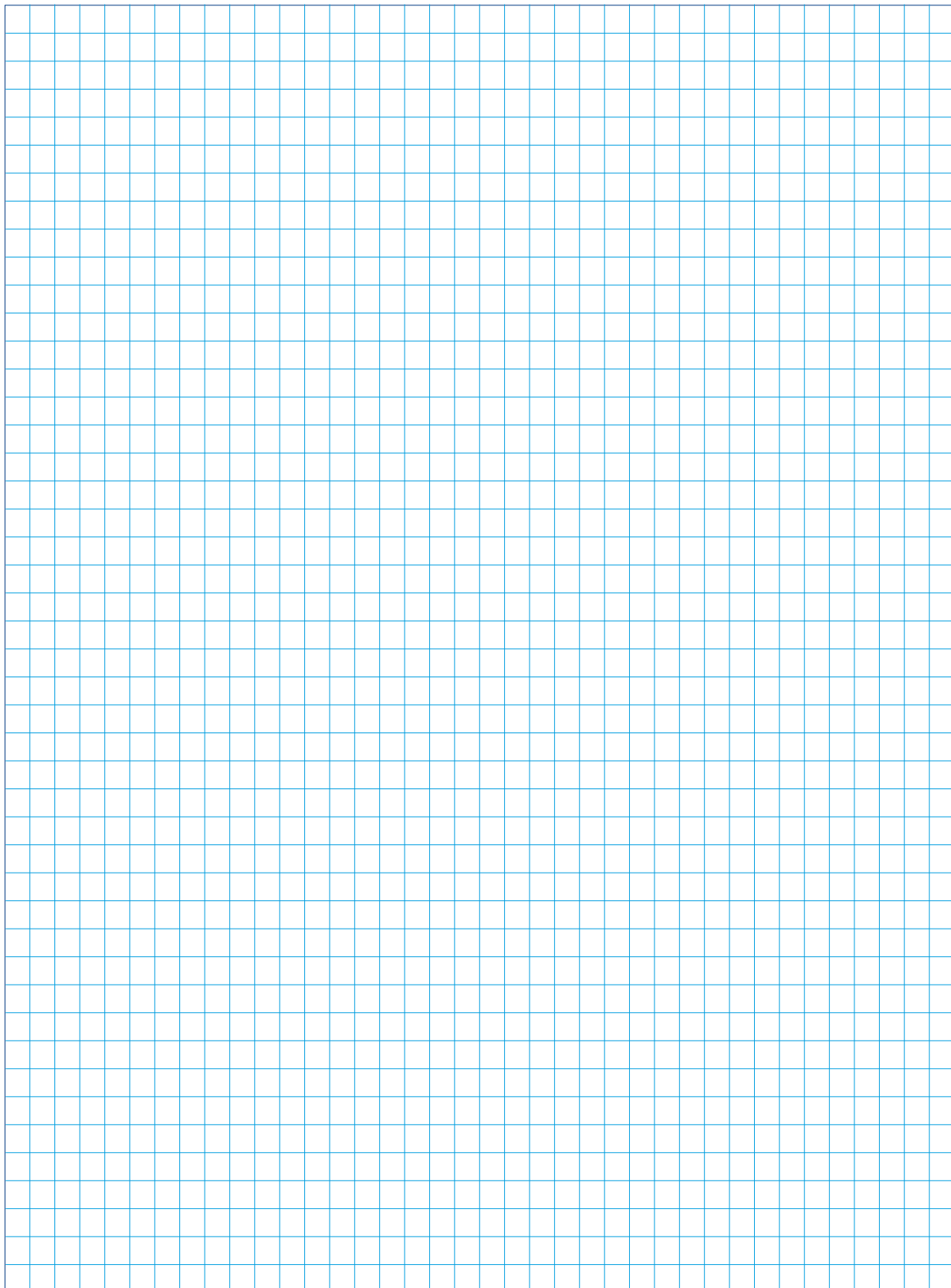

AIRLESS DIAPHRAGM PUMPS



MIRO[®] Rif. 21500



VIKING Rif. 18741



GIOTTO Rif. 12450

MANUFACTURER:

LARIUS

23801 CALOLZIOCORTE - LECCO - ITALY - Via Antonio Stoppani, 21
Tel. (39) 0341/62.11.52 - Fax (39) 0341/62.12.43
E-mail: larius@larius.com - Internet <http://www.larius.com>



DIRECT LINE

CUSTOMERS TECHNICAL SERVICE

Tel. (39) 0341/621256
Fax (39) 0341/621234

